

PNOZ m EF 1MM

PILZ
THE SPIRIT OF SAFETY

- ▶ Configurable, safe small controllers PNOZmulti 2

This document is the original document.

All rights to this documentation are reserved by Pilz GmbH & Co. KG. Copies may be made for the user's internal purposes. Suggestions and comments for improving this documentation will be gratefully received.

Source code from third-party manufacturers or open source software has been used for some components. The relevant licence information is available on the Internet on the Pilz homepage.

Pilz®, PIT®, PMI®, PNOZ®, Primo®, PSEN®, PSS®, PVIS®, SafetyBUS p®, SafetyEYE®, SafetyNET p®, the spirit of safety® are registered and protected trademarks of Pilz GmbH & Co. KG in some countries.



SD means Secure Digital

1	Introduction	6
1.1	Validity of documentation	6
1.2	Using the documentation	6
1.3	Definition of symbols	6
2	Overview	8
2.1	Scope of supply	8
2.2	Unit features	8
2.3	Front view	9
3	Safety	10
3.1	Intended use	10
3.2	System requirements	11
3.3	Safety regulations	11
3.3.1	Safety assessment	11
3.3.2	Use of qualified personnel	11
3.3.3	Warranty and liability	12
3.3.4	Disposal	12
3.3.5	For your safety	12
4	Function description	13
4.1	Operation	13
4.2	Block diagram	13
4.3	Monitoring functions	13
4.3.1	Safe speed monitoring	13
4.3.2	Safe speed range monitoring	15
4.3.3	Safe direction monitoring	16
4.3.4	Safe operating stop monitoring	17
4.3.5	Safe stop 1 monitoring	18
4.3.6	Safe stop 2 monitoring	19
4.3.7	Safely limited acceleration monitoring (SLA-M)	21
4.3.8	Safely limited acceleration range monitoring (SAR-M)	22
4.3.9	Central motion monitoring functions	23
4.4	System reaction time	24
4.5	Proximity switch	25
4.6	Encoder	26
4.6.1	Output signals	28
4.6.2	Adapters for encoders	29
5	Installation	30
5.1	General installation guidelines	30
5.2	Dimensions in mm	30
5.3	Connect the base unit and expansion modules	31
6	Commissioning	32
6.1	Wiring	32
6.2	Pin assignment of Mini-IO socket	32
6.3	Connection of proximity switches	33

6.4	Connection of an encoder	34
6.4.1	Connect encoder	36
6.4.2	Connect encoder with Z index	36
6.4.3	Connect encoder via an adapter	37
6.5	Connection of proximity switch and encoder	37
6.6	EMC-compliant wiring	39
6.7	Download modified project to the PNOZmulti system	43
7	Operation	44
7.1	LED indicators	44
7.2	Behaviour with implausible sensor signals	44
8	Technical details	45
8.1	Safety characteristic data	47
9	Supplementary data	48
9.1	Categories	48
9.1.1	Safety level	48
9.1.2	Safety functions	49
9.1.3	Safety-related characteristic data for operation with non-safety-related encoder without additional requirements	50
9.1.3.1	Permitted sensor types and output signals	50
9.1.3.2	Safety-related architecture	50
9.1.3.3	Achievable safety level	50
9.1.4	Safety-related characteristic data for operation with non-safety-related encoder with mechanical fault exclusion	51
9.1.4.1	Permitted sensor types and output signals	51
9.1.4.2	Safety-related architecture	51
9.1.4.3	Achievable safety level	52
9.1.5	Safety-related characteristic data for operation with non-safety-related encoder with diagnostics via the drive controller	52
9.1.5.1	Permitted sensor types and output signals	52
9.1.5.2	Requirements of the drive controller	52
9.1.5.3	Safety-related architecture	53
9.1.5.4	Achievable safety level	53
9.1.6	Safety-related characteristic data for operation with a safe encoder	54
9.1.6.1	Permitted sensor types and output signals	54
9.1.6.2	Safety-related architecture	54
9.1.6.3	Achievable safety level	55
9.1.7	Safety-related characteristic data for operation with a safe encoder with Z index	55
9.1.7.1	Permitted sensor types and output signals	55
9.1.7.2	Safety-related architecture	55
9.1.7.3	Achievable safety level	56
9.1.8	Safety-related characteristic data for operation with non-safety-related encoder and proximity switch	56
9.1.8.1	Permitted sensor types and output signals	56
9.1.8.2	Safety-related architecture	57
9.1.8.3	Achievable safety level	57
9.1.9	Safety-related characteristic data for operation with 2 proximity switches	58

9.1.9.1	Permitted sensor types and output signals.....	58
9.1.9.2	Safety-related architecture.....	58
9.1.9.3	Achievable safety level.....	59
9.1.10	Safety characteristic data for operation with 2 proximity switches with reduced diagnostics ...	59
9.1.10.1	Permitted sensor types and output signals.....	59
9.1.10.2	Safety-related architecture.....	60
9.1.10.3	Achievable safety level.....	60
10	Order reference	61
10.1	Product	61
10.2	Accessories	61

1 Introduction

1.1 Validity of documentation

This documentation is valid for the product PNOZ m EF 1MM from Version 2.2.

This operating manual explains the function and operation, describes the installation and provides guidelines on how to connect the product.

1.2 Using the documentation

This document is intended for instruction. Only install and commission the product if you have read and understood this document. The document should be retained for future reference.

1.3 Definition of symbols

Information that is particularly important is identified as follows:



DANGER!

This warning must be heeded! It warns of a hazardous situation that poses an immediate threat of serious injury and death and indicates preventive measures that can be taken.



WARNING!

This warning must be heeded! It warns of a hazardous situation that could lead to serious injury and death and indicates preventive measures that can be taken.



CAUTION!

This refers to a hazard that can lead to a less serious or minor injury plus material damage, and also provides information on preventive measures that can be taken.



NOTICE

This describes a situation in which the product or devices could be damaged and also provides information on preventive measures that can be taken. It also highlights areas within the text that are of particular importance.



INFORMATION

This gives advice on applications and provides information on special features.

2 Overview

2.1 Scope of supply

- ▶ Expansion module PNOZ m EF 1MM
- ▶ Jumper

2.2 Unit features

Application of the product PNOZ m EF 1MM:

Expansion module for connection to a base unit from the PNOZmulti 2 system.

The product has the following features:

- ▶ Can be configured in the PNOZmulti Configurator
- ▶ Monitoring of 1 axis
- ▶ Measured value recorded by proximity switch and encoder
- ▶ Monitoring functions
 - Safe speed monitoring (SSM)
 - Safe speed range monitoring (SSR-M)
 - Safe direction of movement monitoring (SDI-M)
 - Safe operating stop monitoring (SOS-M)
 - Safe stop 1 monitoring (SS1-M)
 - Safe stop 2 monitoring (SS2-M)
 - Safely limited acceleration monitoring (SLA-M)
 - Safely limited acceleration range monitoring (SAR-M)
 - Analogue voltage (track S)
- ▶ LED display for:
 - Supply voltage
 - Diagnostics
 - Axis status
 - Fault
- ▶ Please refer to the document "PNOZmulti System Expansion" for details of the base units PNOZmulti 2 that can be connected.
- ▶ Plug-in connection terminals:

Either spring-loaded terminal or screw terminal available as an accessory (see Order references for accessories).

2.3 Front view

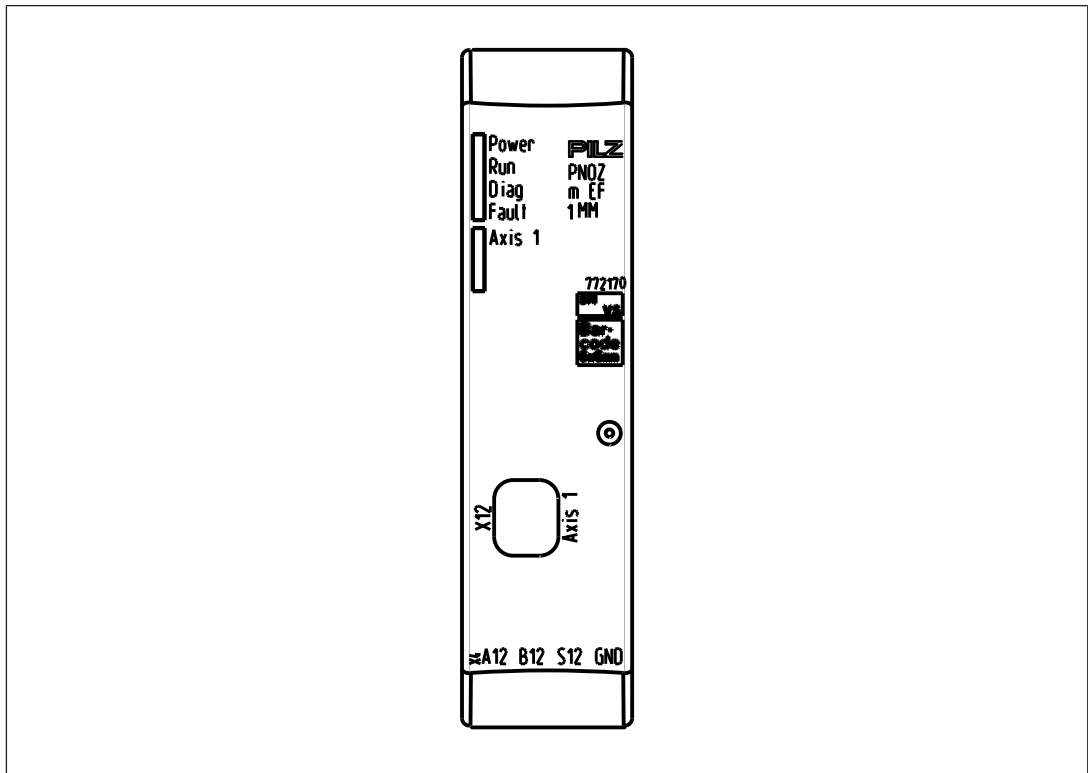

Legend:

- ▶ X4: Connection for proximity switch at axis 1
- ▶ X12: Mini IO socket for connecting encoder or proximity switch at axis 1.
- ▶ LEDs:
 - Power
 - Run
 - Diag
 - Fault
 - Axis 1

3 Safety

3.1 Intended use

The motion monitoring expansion module monitors safety functions in accordance with EN 61800-5-2 for safe motion monitoring.

The following monitoring functions are performed:

- ▶ Safe direction monitoring (SDI-M)
- ▶ Safe operating stop monitoring (SOS-M)
- ▶ Safe speed range monitoring (SSR-M)
- ▶ Safe speed monitoring (SSM)
- ▶ Safe stop 1 monitoring (SS1-M)
- ▶ Safe stop 2 monitoring (SS2-M)
- ▶ Safely limited acceleration monitoring (SLA-M)
- ▶ Safely limited acceleration range monitoring (SAR-M)

The expansion module meets the requirements of EN IEC 61508 up to SIL 3 and EN ISO 13849-1 up to PL e.

The expansion module may only be connected to a base unit from the configurable system PNOZmulti 2 (please refer to the document "PNOZmulti System Expansion" for details of the base units that can be connected).

The configurable system PNOZmulti 2 is used for the safety-related interruption of safety circuits and is designed for use in:

- ▶ Emergency stop equipment
- ▶ Safety circuits in accordance with VDE 0113 Part 1 and EN 60204-1
- ▶ The product PNOZ m EF 1MM meets the requirements of the standards EN 81-20, EN 81-22 and EN 81-50, harmonised under the Lifts Directive 2014/33/EU, and the requirements of the standard EN 115-1, harmonised under the Machinery Directive 2006/42/EC.
- ▶ The programmable safety system should be installed in a protected environment that meets at least the requirements of pollution degree 2.

Example: Protected inside space or control cabinet with protection type IP54 and corresponding air conditioning.

The following is deemed improper use in particular

- ▶ Any component, technical or electrical modification to the product,
- ▶ Use of the product outside the areas described in this manual,
- ▶ Use of the product outside the technical details (see [Technical details](#)  45).

**NOTICE****EMC-compliant electrical installation**

The product is designed for use in an industrial environment. The product may cause interference if installed in other environments. If installed in other environments, measures should be taken to comply with the applicable standards and directives for the respective installation site with regard to interference.

3.2 System requirements

Please refer to the "Product Modifications PNOZmulti" document in the "Version overview" section for details of which versions of the base unit and PNOZmulti Configurator can be used for this product.

3.3 Safety regulations

3.3.1 Safety assessment

Before using a device it is necessary to perform a safety assessment in accordance with the Machinery Directive.

Functional safety is guaranteed for the product as a single component. However, this does not guarantee the functional safety of the overall plant/machine. In order to achieve the required safety level for the overall plant/machine, define the safety requirements for the plant/machine and then define how these must be implemented from a technical and organisational standpoint.

3.3.2 Use of qualified personnel

The products may only be assembled, installed, programmed, commissioned, operated, maintained and decommissioned by competent persons.

A competent person is someone who, because of their training, experience and current professional activity, has the specialist knowledge required to test, assess and operate the work equipment, devices, systems, plant and machinery in accordance with the general standards and guidelines for safety technology.

It is the company's responsibility only to employ personnel who

- ▶ Are familiar with the basic regulations concerning health and safety / accident prevention,
- ▶ Have read and understood the information provided in this description under "Safety",
- ▶ And have a good knowledge of the generic and specialist standards applicable to the specific application.

3.3.3 Warranty and liability

All claims to warranty and liability will be rendered invalid if

- ▶ The product was used contrary to the purpose for which it is intended,
- ▶ Damage can be attributed to not having followed the guidelines in the manual,
- ▶ Operating personnel are not suitably qualified,
- ▶ Any type of modification has been made (e.g. exchanging components on the PCB boards, soldering work etc.).

3.3.4 Disposal

- ▶ In safety-related applications, please comply with the mission time T_M in the safety-related characteristic data.
- ▶ When decommissioning, please comply with local regulations regarding the disposal of electronic devices (e.g. Electrical and Electronic Equipment Act).

3.3.5 For your safety

The unit meets all the necessary conditions for safe operation. However, you should always ensure that the following safety requirements are met:

- ▶ This operating manual only describes the basic functions of the unit. The expanded functions are described in the PNOZmulti Configurator's online help. Only use these functions once you have read and understood the documentations.
- ▶ Do not open the housing or make any unauthorised modifications.
- ▶ Please make sure you shut down the supply voltage when performing maintenance work (e.g. exchanging contactors).

4 Function description

4.1 Operation

The motion monitoring module PNOZ m EF 1MM can monitor one axis. The motion monitoring module signals the status of the monitored values to the base unit. Depending on the implemented safety circuit, the values may be transferred from the base unit to an output on the control system. Proximity switches or encoders are used to record the values.

The configuration of the motion monitoring module is described in detail in the PNOZmulti Configurator's online help.

The relay meets the following safety requirements:

- ▶ The circuit is redundant with built-in self-monitoring.
- ▶ The safety device remains effective in the case of a component failure.

4.2 Block diagram

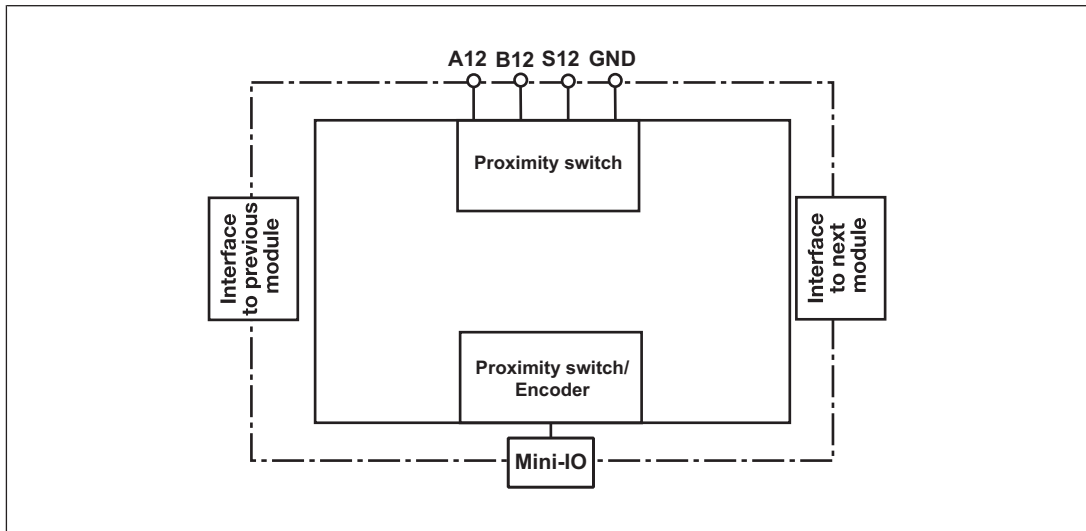

4.3 Monitoring functions

The motion monitoring module PNOZ m EF 1MM supports the following monitoring functions.

Please note that the position monitoring functions SOS-M, SDI-M and SS2-M cannot be used in conjunction with 2 proximity switches, as no position can be detected.

4.3.1 Safe speed monitoring

The **Safe speed monitoring** function (SSM) monitors the current speed to see if a limit value is exceeded.

If the configured limit value is exceeded, the output switches off. As soon as the value falls below the limit value (plus hysteresis), the output switches off again.

If a manual reset is configured, the output will not switch back on until the value is inside the limit value (plus hysteresis) and the reset input is activated.

In PNOZmulti Configurator 12 areas can be configured per axis (with units < Version 2.0 only 8 limit values can be configured).

A tolerance range may also be set for the limit values used to monitor the speed. This tolerance range modifies the set limit values. As a result, one-off or periodic overshoots that exceed the limit values can be tolerated.

The following values can be configured for the tolerance range:

- ▶ Tolerance time (t_1), which takes into account the length of the overshoots (maximum time for which the limit value may be exceeded). It must not be possible that the sum of all the overshoots exceeds the tolerance time (t_1) within a tolerance period (t_2).
- ▶ Tolerance period (t_2), which takes into account the oscillation period (minimum time that must elapse between one limit value overshoot and the next)
- ▶ Tolerance amount (%), which takes into account the amplitude of the overshoots (maximum permitted percentage by which the configured limit values may be exceeded)

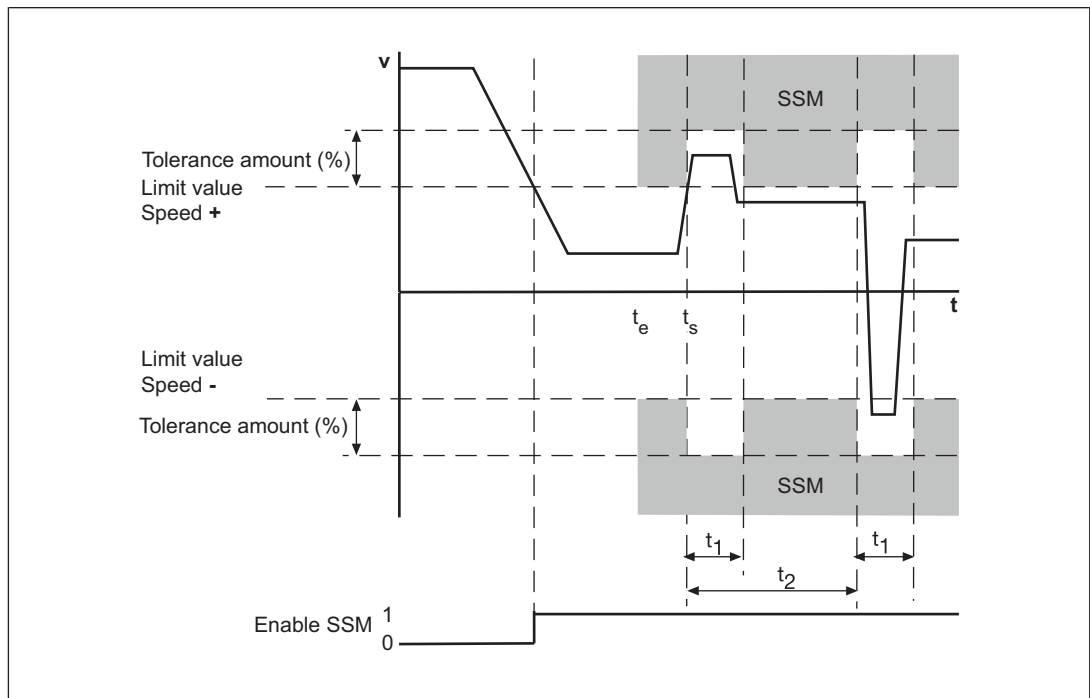

Legend:

▶ Enable SSM:

- "1": Monitored limit value not exceeded
- "0": Monitored limit value exceeded

- ▶ t_s : Speed v exceeds the limit value and activates the tolerance range (tolerance time, tolerance period, tolerance amount)
- ▶ t_1 : Tolerance time
- ▶ t_2 : Tolerance period
- ▶ Tolerance amount (%): Tolerance amount of limit value in both directions

4.3.2 Safe speed range monitoring

The **Safe speed range monitoring** function (SSR-M) monitors the current speed to ensure it stays within a maximum and minimum permitted limit value.

If the speed is outside the configured range, the output switches off. As soon as the speed returns within the configured range (plus hysteresis), the output switches back on.

If manual reset is configured, the output will not switch back on until the value is below the limit value (plus hysteresis) and the reset input is activated.

In PNOZmulti Configurator 2 areas can be configured per axis (with units < Version 2.0 only 1 area can be configured).

A tolerance range may also be set for the limit values used to monitor the speed range. This tolerance range modifies the set limit values. As a result, one-off or periodic overshoots that exceed the range limits can be tolerated.

The following values can be configured for the tolerance range:

- ▶ Tolerance time (t_1), which takes into account the length of the overshoots (maximum time for which the limit value may be exceeded). It must not be possible that the sum of all the overshoots exceeds the tolerance time (t_1) within a tolerance period (t_2).
- ▶ Tolerance period (t_2), which takes into account the oscillation period (minimum time that must elapse between one limit value overshoot and the next)
- ▶ Tolerance amount as a %, which takes into account the amplitude of the overshoots (maximum permitted percentage by which the limit value may be exceeded)

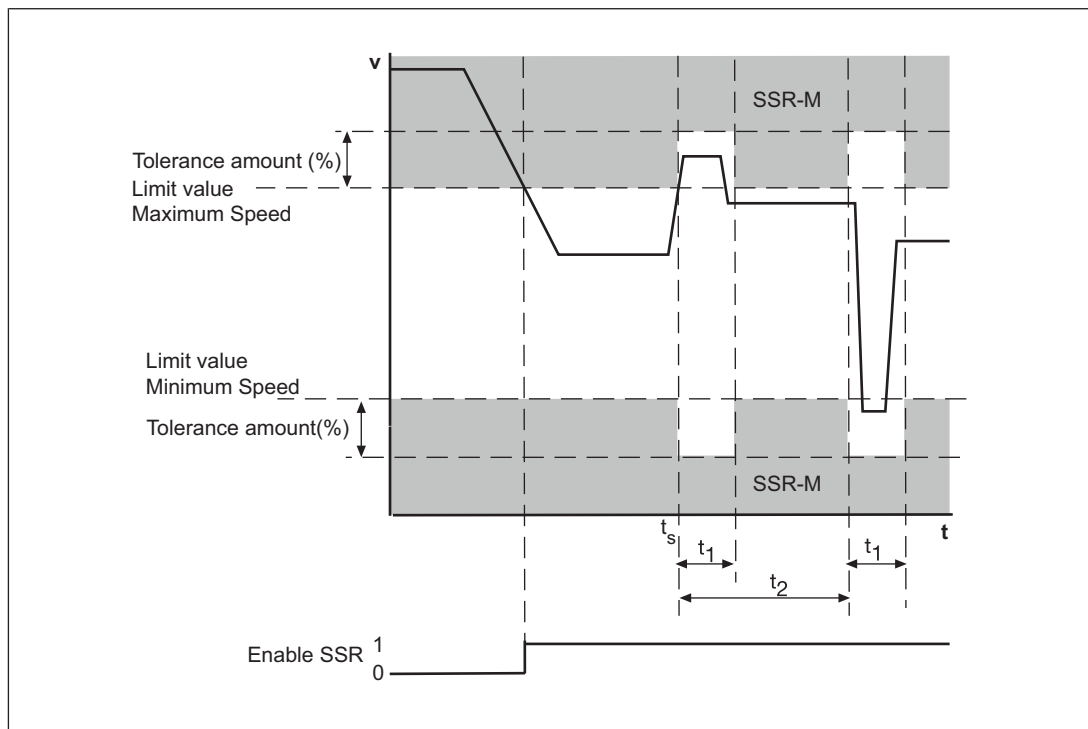

Legend:

- ▶ Enable SSR:
 - "1": Speed is within the configured range
 - "0": Speed is outside the configured range

- ▶ t_s : Speed v exceeds the limit value and activates the tolerance range (tolerance time, tolerance period, tolerance amount)
- ▶ t_1 : Tolerance time
- ▶ t_2 : Tolerance period
- ▶ Tolerance amount (%): Tolerance amount of the two limit values, maximum and minimum speed

4.3.3 Safe direction monitoring

The **Safe direction monitoring** function (SDI-M) monitors the direction of movement defined for the drive axis (positive or negative). Safe direction of movement monitoring is activated via the start input. It remains active until the configured tolerance is exceeded in the opposite direction. The function can be retriggered at any time by a rising edge at the start input. As a result, the current position can be used at any time as the start point for the monitoring function.

One SDI-M element can be configured per axis for each direction in the PNOZmulti Configurator.

Please note:

This monitoring function cannot be used in conjunction with 2 proximity switches because position detection is not possible.



WARNING!

Potential loss of safety function with a tolerance value >24,900,000 increments!

The following applies when using a PNOZmulti Configurator **Version <10.0**: If a tolerance value >24,900,000 increments is configured in the PNOZmulti Configurator, the monitoring function will no longer be evaluated correctly. Depending on the application, serious injury or death may result. Make sure that a tolerance value <24,900,000 increments is configured. From Version 10.0 of the PNOZmulti Configurator, the feasibility of the value will be checked automatically.

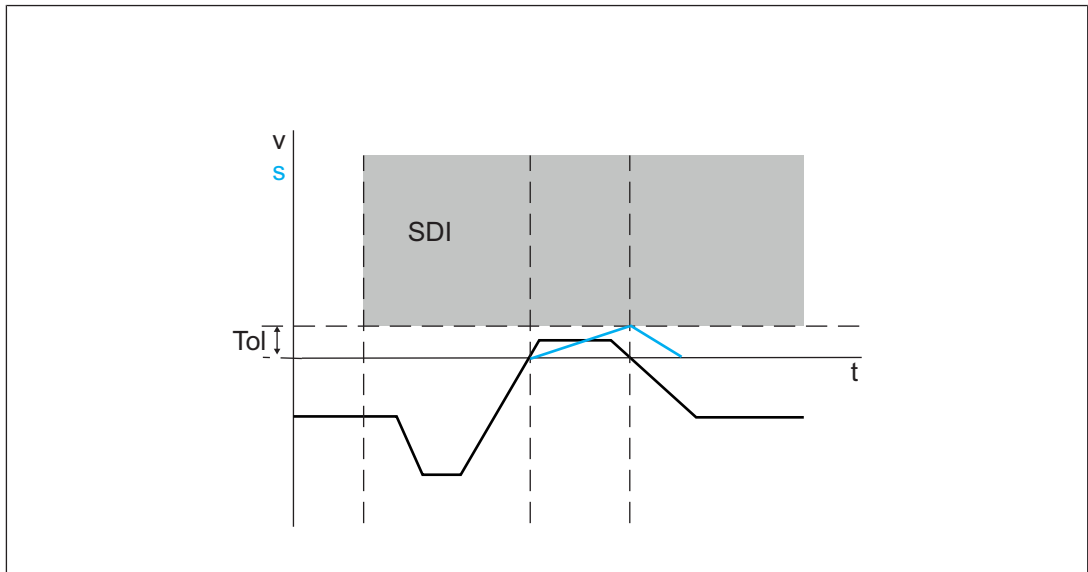

4.3.4 Safe operating stop monitoring

The **Safe operating stop monitoring** function (SOS-M) monitors whether the stop position remains within a configured tolerance window. Safe operating stop monitoring is activated within a rising edge at the start input. It remains active until the value is outside the tolerance band. The function can be retriggered at any time by a rising edge at the start input. As a result, the current position can be used at any time as the start point for the monitoring function.

In PNOZmulti Configurator 3 elements SOS-M can be configured per axis (with units < Version 2.0 only 1 element can be configured).

Please note:

This monitoring function cannot be used in conjunction with 2 proximity switches because position detection is not possible.



WARNING!

Potential loss of safety function with a tolerance value >24,900,000 increments!

The following applies when using a PNOZmulti Configurator **Version <10.0**: If a tolerance value >24,900,000 increments is configured in the PNOZmulti Configurator, the monitoring function will no longer be evaluated correctly. Depending on the application, serious injury or death may result. Make sure that a tolerance value <24,900,000 increments is configured. From Version 10.0 of the PNOZmulti Configurator, the feasibility of the value will be checked automatically.

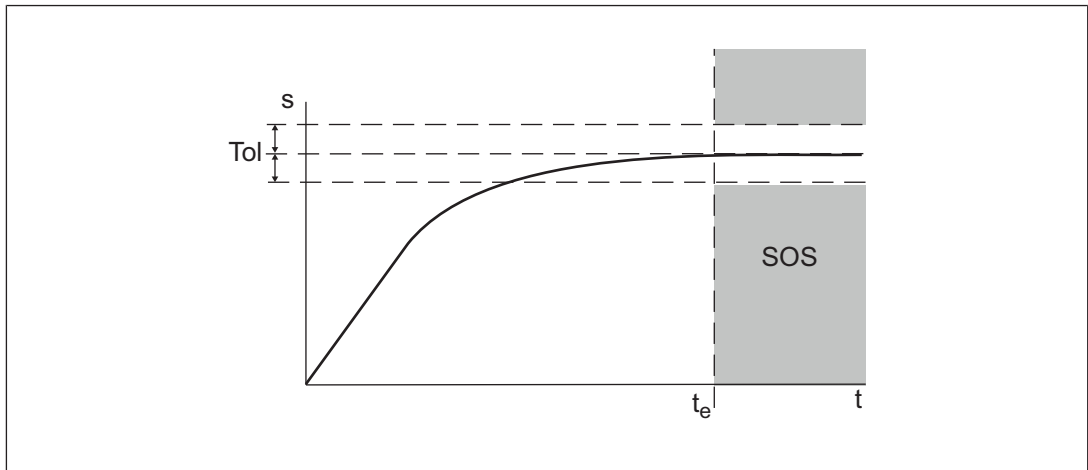

Legend:

- ▶ t_e : Activation of the monitoring function SOS

4.3.5 Safe stop 1 monitoring

The **Safe stop 1 monitoring** function (SS1-M) monitors whether the set delay time has elapsed (until controlled braking of the motor) or the standstill limit value for automatic STO is below the limit value.

- ▶ If the monitoring function SS1-M is triggered, the **Braking ramp** output is switched off. The drive controller's braking ramp is activated.
- ▶ After the set delay time has elapsed or the value for the automatic STO is below the limit value, the output **ST** switches off. The safety function **Safe torque off** (STO) is activated.

A maximum of 1 SS1-M element can be configured per axis in the PNOZmulti Configurator.

Sequence without standstill limit value for automatic STO:

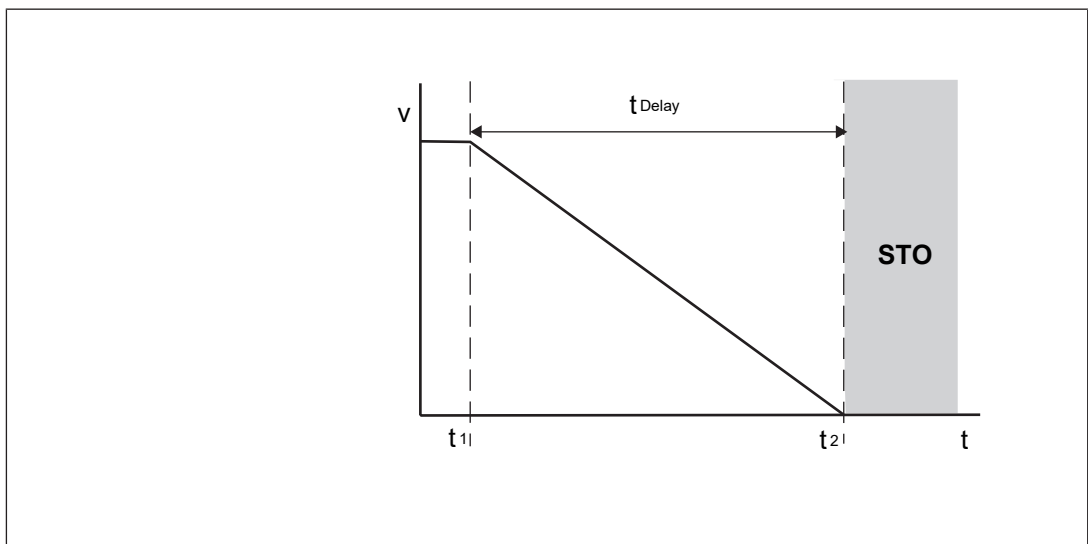

Legend

- t_1 : Monitoring function SS1-M is activated
- t_2 : Delay time elapses, safety function "Safe torque off" (STO) is activated
- t_{Delay} : Set delay time for controlled braking of motor

Sequence with standstill limit value for automatic STO:

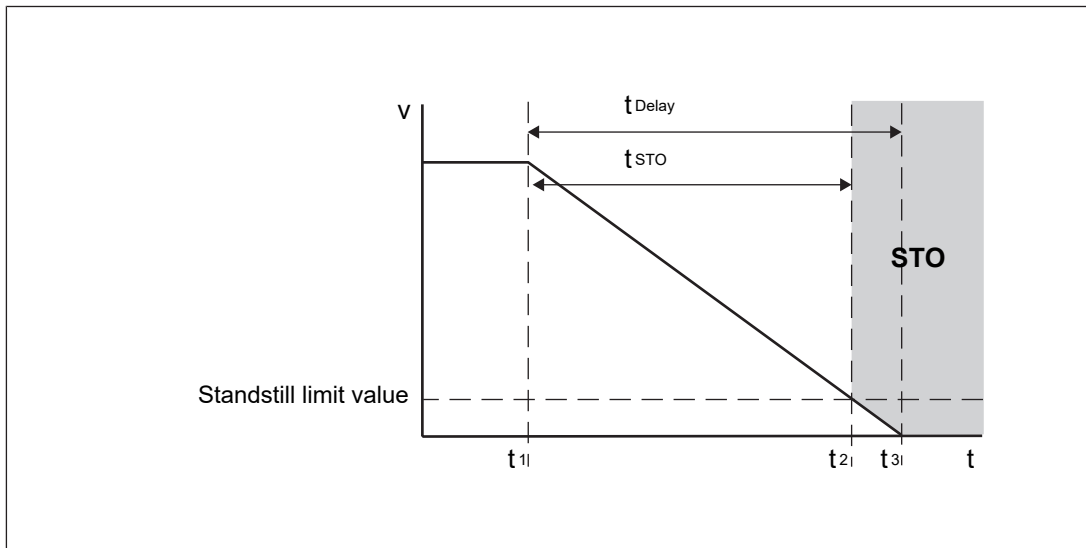

Legend

- t_1 : Monitoring function SS1-M is activated
- t_2 : Standstill limit value for automatic STO reached, safety function "Safe torque off" (STO) is activated
- t_3 : Delay time elapses
- t_{Delay} : Set delay time for controlled braking of motor
- t_{STO} : Actual time from activation of monitoring function until STO is activated

4.3.6 Safe stop 2 monitoring

The **Safe stop 2 monitoring** function (SS2-M) monitors

- ▶ Whether the set delay time has expired (until controlled braking of the motor) or the standstill limit value for automatic SOS is below the limit value.
- and
- ▶ Whether the stop position ultimately remains within a configured tolerance window.

Reaction:

- ▶ If the monitoring function SS2-M is triggered, the "Braking ramp" output switches off. The drive controller's braking ramp is activated.
- ▶ If the set delay time has elapsed or the value for the automatic SOS is below the limit value, the stop position is monitored, the **Position monitoring** output switches on. If the stop position is outside the tolerance window, the **Position monitoring** and **STO** outputs switch off, the safety function **Safe torque off** (STO) is activated.

A maximum of 1 SS2-M element can be configured per axis in the PNOZmulti Configurator.

Please note:

This monitoring function cannot be used in conjunction with 2 proximity switches because position detection is not possible.

Sequence without standstill limit value for automatic SOS:

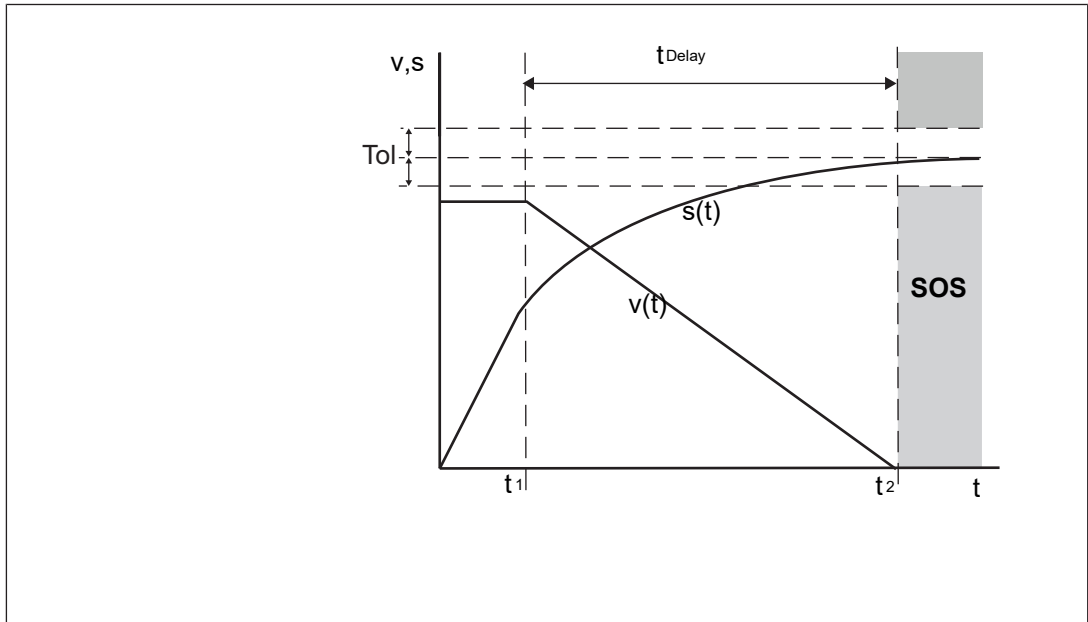

Legend

- t_1 : Activation of the monitoring function SS2-M
- t_2 : Delay time elapses, monitoring of stop position (SOS) is activated
- t_{Delay} : Set delay time for controlled braking of motor

Sequence with standstill limit value for automatic SOS:

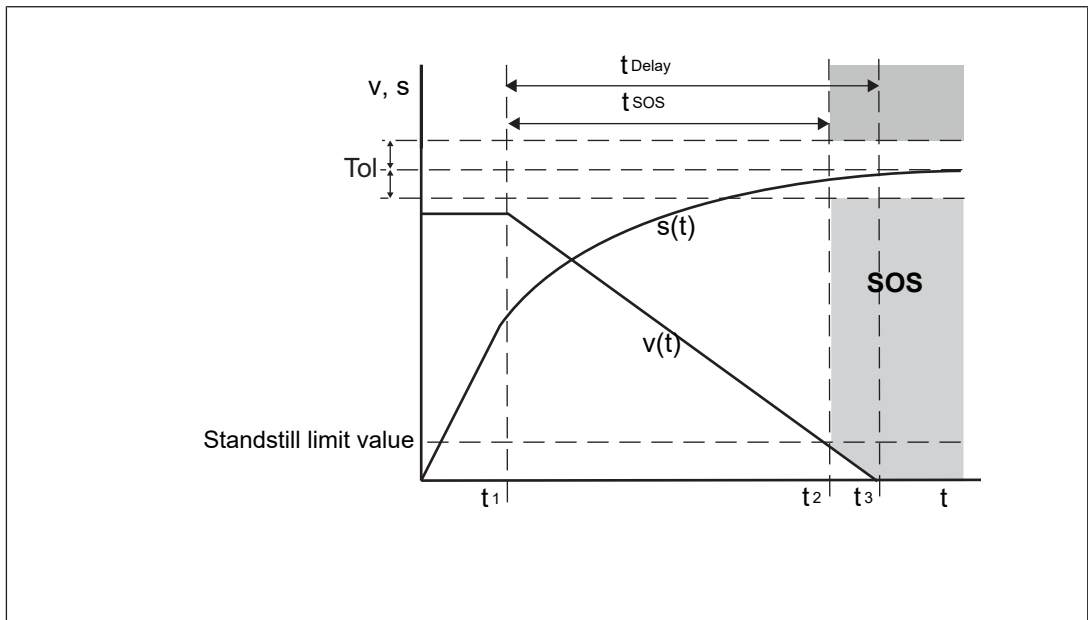

Legend

- t_1 : Activation of the monitoring function SS2-M
- t_2 : Standstill limit value for automatic SOS reached, monitoring of stop position (SOS) is activated
- t_3 : Delay time elapses
- t_{Delay} : Set delay time for controlled braking of motor

t_{STO} : Actual time from activation of monitoring function until STO is activated

Sequence when stop position is violated:

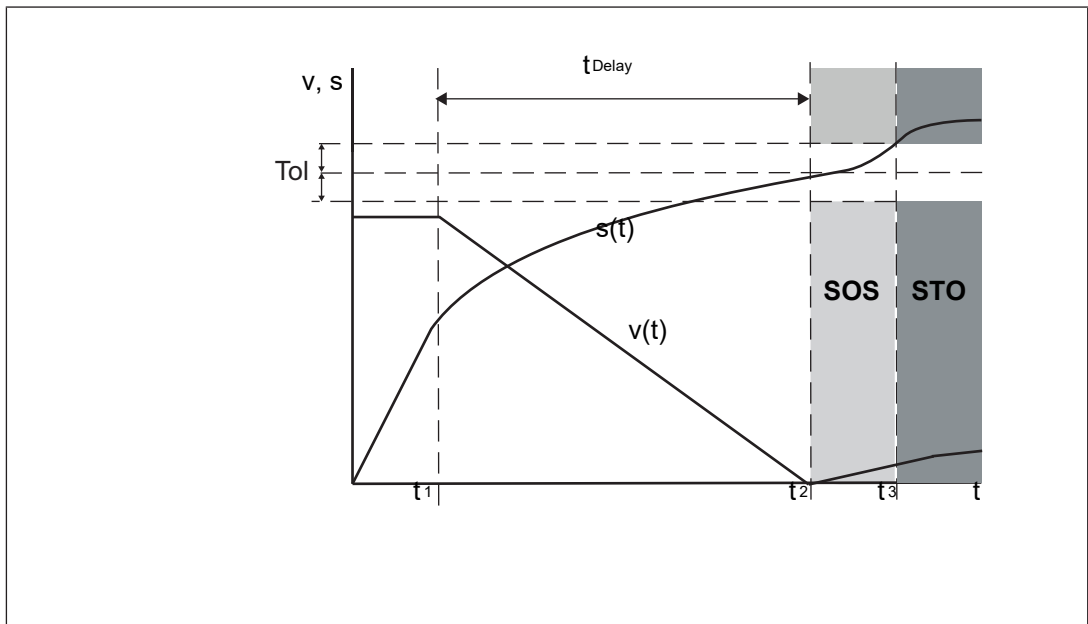

Legend

- t_1 : Activation of the monitoring function SS2-M
- t_2 : Standstill limit value for automatic SOS reached, monitoring of stop position (SOS) is activated
- t_3 : Stop position outside of tolerance window, safety function "Safe torque off" (STO) is activated
- t_{Delay} : Set delay time for controlled braking of motor

4.3.7 Safely limited acceleration monitoring (SLA-M)

The monitoring function **Safely limited acceleration monitoring** monitors the speed change per time unit.

Both the acceleration and the deceleration can be monitored.

Monitoring checks whether the acceleration or deceleration exceeds or falls below a certain limit value.

4 SLA-M elements can be configured per axis in the PNOZmulti Configurator.

The monitoring function **Safely limited acceleration monitoring** is activated with a rising edge at the start input. The trigger detection phase starts with a falling edge at the start input. In this process the current speed is taken as the start speed.

Monitoring of safely limited acceleration starts,

- ▶ when the trigger threshold is passed, that is, when the start speed changes by the configured percentage (V1).
- ▶ When monitoring starts within the maximum trigger time (t_1).

When monitoring is started, the set acceleration is calculated as a straight line V_{Set} . A tolerance band $V_{Tolerance}$ is calculated from the Tolerance and V_{Edge} parameters. If the actual speed V_{Actual} leaves the tolerance band, the output **Enable SLA** switches off.

Monitoring is ended,

- ▶ When monitoring is reset by a rising edge at the start input,
- ▶ When a range has been violated and it is no longer possible to return within the valid range,
- ▶ When the target speed is passed.

Example: Monitoring for too fast acceleration

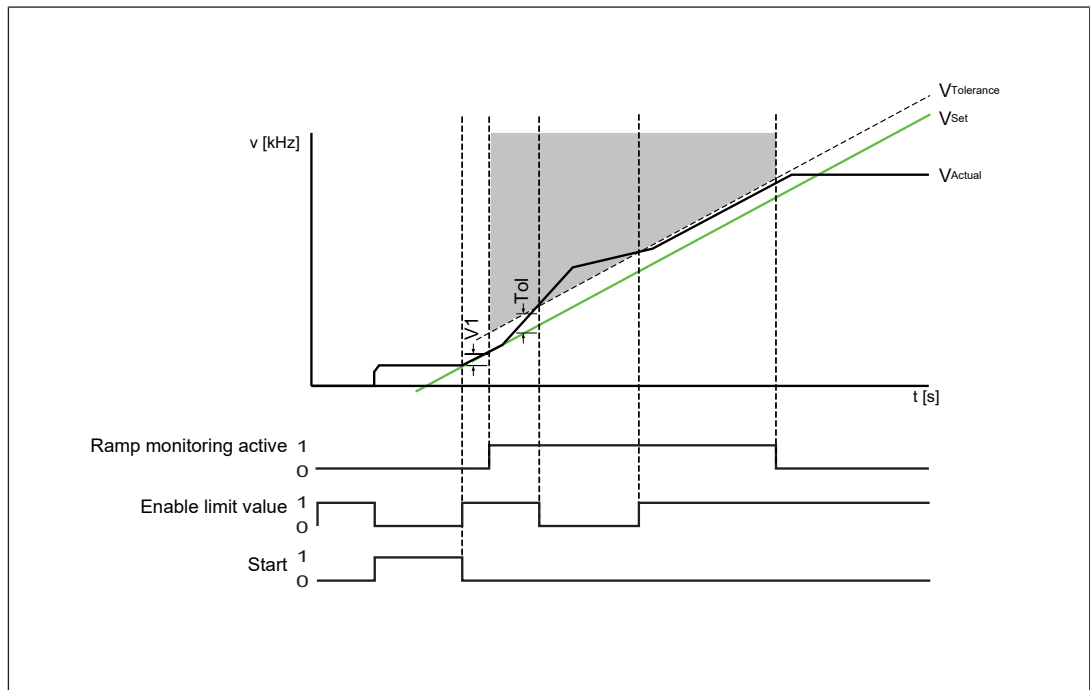

4.3.8 Safely limited acceleration range monitoring (SAR-M)

The monitoring function **Safely limited acceleration monitoring** monitors the speed change per time unit.

In contrast to the monitoring function SLA-M, safely limited acceleration range monitoring monitors not only a limit value but also the upper and lower limit value simultaneously. Both the acceleration and the deceleration can be monitored.

Otherwise the functionality is the same as the monitoring function SLA-M.

4 SAR-M elements can be configured per axis in the PNOZmulti Configurator.

Example: Monitoring for too fast and too slow acceleration

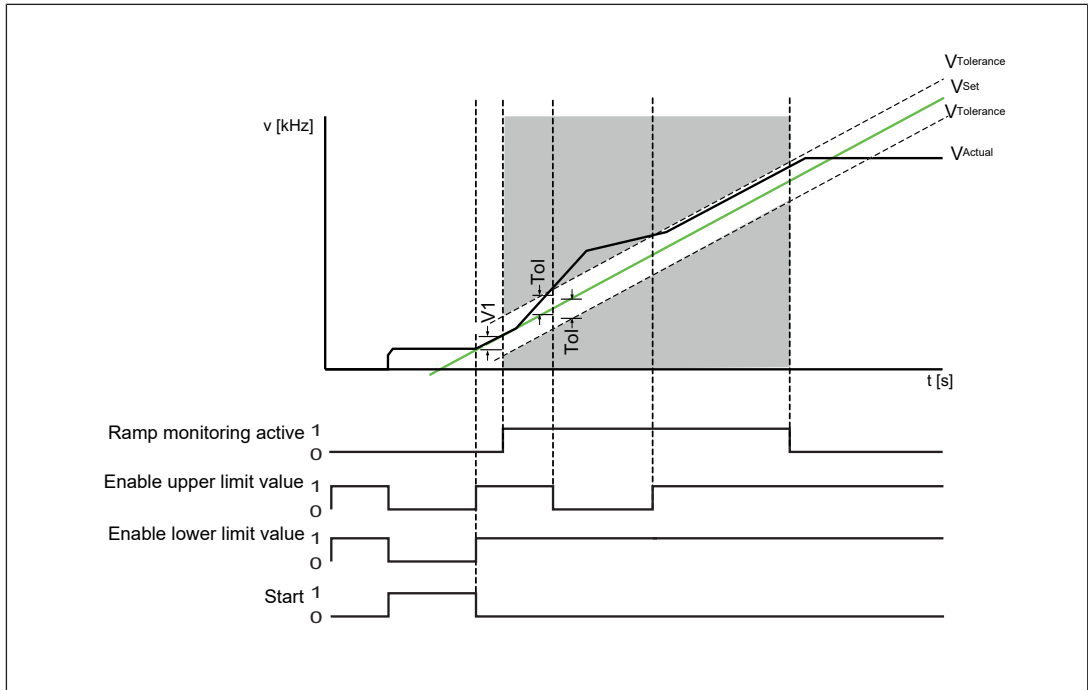

4.3.9 Central motion monitoring functions

These functions apply centrally for all the monitoring functions.

Hysteresis

A central hysteresis can be configured for the monitoring functions. This prevents the outputs from bouncing if there are fluctuations around the response value. The hysteresis takes effect when the output is switched on.

Validation cut-off frequency

As implausible sensor signals may arise due to jitter on the sensors around the stop position, a central validation cut-off frequency must be configured for sensor types with proximity switches in the PNOZmulti Configurator (edge jitter is caused by the position control of the drive frequency converter or by external interference signals).

If the value of the validation cut-off frequency falls below the configured value, the feasibility check of the sensors will no longer be run.

Advanced Settings tab

A tolerance time can be configured for tracks AB, Z and S respectively.

The tolerance time influences the sensitivity towards invalid signal levels (e.g. in the event of EMC interference).

The greater the configured tolerance time, the less sensitive the system will be towards invalid signal levels.

The tolerance time can be deactivated for individual tracks by setting 0 ms.



CAUTION!

Delayed reaction to invalid signal levels

Setting a tolerance time increases the reaction time of the feasibility check of the signal levels. The detection time can increase to a maximum of four times the set tolerance time as a result. This must be taken into account when the system is designed.

4.4 System reaction time

Calculation of the maximum reaction time between an input switching off and a linked output in the system switching off is described in the document "PNOZmulti System Expansion".

4.5 Proximity switch

- ▶ Proximity switches can be used with a pnp or npn output.
- ▶ The proximity switches must be fitted so that at least one is always activated. In other words, the proximity switches must be fitted so that the recorded signals always overlap.
- ▶ The cable used to connect the proximity switches must be shielded (see connection diagrams in the chapter entitled "EMC-compliant wiring").
- ▶ A DC voltage in the range of 0 - 30 V can be monitored via track S. It should be used to monitor the supply voltage of the proximity switches.



CAUTION!

Please note: Connection of the proximity switches may only be performed in three-wire technology and not in two-wire technology.

Proximity switch assembly:

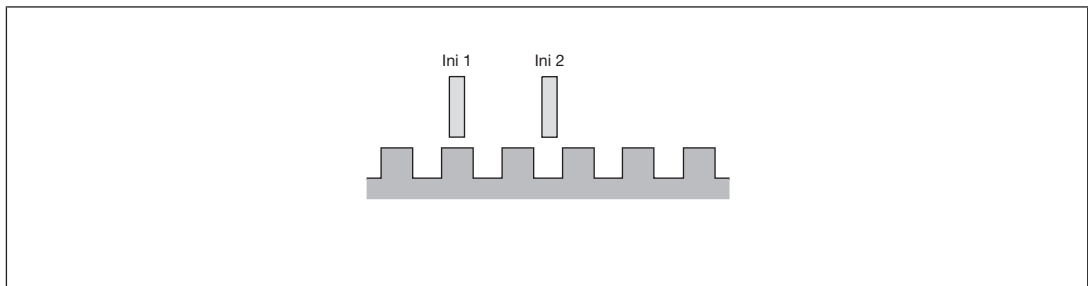

Signal characteristics:

Proximity switch combinations	Signal image in an energised state
PNP / PNP	<p> Ini 1: energised (high), De-energised (low) Ini 2: energised (low), De-energised (high) > 1% of period length </p>
NPN / NPN	<p> Ini 1: De-energised (low), energised (high) Ini 2: De-energised (high), energised (low) > 1% of period length </p>
NPN / PNP	<p> Ini 1: De-energised (low), energised (high) Ini 2: energised (low), De-energised (high) > 1% of period length </p>

Proximity switch combinations	Signal image in an energised state
PNP / NPN	<p>Ini 1 energised De-energised</p> <p>Ini 2 De-energised energised</p> <p>> 1% of period length</p>



WARNING!

Potential loss of safety function due to implausible signals from the proximity switch

Depending on the application, serious injury or death may result.

- Make sure that the proximity switches are installed as described in the operating manual and that only those combinations described in the signal characteristics table are used.
- Appropriate installation measures should be taken to prevent a foreign body coming between the signal encoder and the proximity switch. If not, the foreign body could cause invalid signals.
- Please note the values stated in the sensor's technical details.

- ▶ For a full configuration, the maximum frequency of the sensors you are using must be entered in the PNOZmulti Configurator (see sensor's data sheet).

Special features for proximity switches with reduced diagnostics

- ▶ A: pnp, B: pnp
- ▶ It is permitted that both proximity switches are energised simultaneously.
- ▶ The safety level is reduced.
- ▶ The cables for connecting the proximity switches must be laid separately.
- ▶ The supply voltage of the proximity switches must be monitored (e.g. via track S).

4.6 Encoder

- ▶ The following encoders can be used:
 - TTL, HTL (single-ended or differential signals)
 - Sin/Cos 1 Vss
 - Hiperface®
- ▶ The encoders can be connected with or without Z index (0 index).
- ▶ The cables used to connect the encoders must be shielded (see connection diagrams in the chapter entitled "EMC-compliant wiring").

- ▶ A proximity switch can also be connected to track Z to monitor for broken shearpins.

Please note:

Broken shearpin monitoring only becomes active when

- The minimum speed is exceeded
- and
- The tolerance for detecting feasibility errors has elapsed.

The minimum speed and tolerance depend on the ratio of the frequency on tracks AB " f_{AB} " to the frequency on track Z " f_Z " in your configuration (see PNOZmulti Configurator **Motion Monitor Element, Calculated Ratio AB/Z**).

Minimum speed:

- Calculated ratio $AB/Z \geq 1.0$
 $f_Z = 10 \text{ mHz}$ or $f_{AB} = (f_{AB}/f_Z) \times 10 \text{ mHz}$
- when $f_{AB}/f_Z \text{ Ratio} < 1.0$
 $f_{AB} = 10 \text{ mHz}$ or $f_Z = 10 \text{ mHz}/(f_{AB}/f_Z)$

Tolerance for detecting feasibility errors:

- when $f_{AB}/f_Z \text{ Ratio} \geq 1.0$
 $7.5 Z$ pulses or $7.5 \times (f_{AB}/f_Z)$ AB pulses
- when $f_{AB}/f_Z \text{ Ratio} < 1.0$
 $4.5 AB$ pulses or $4.5 \times (f_{AB}/f_Z)$ Z pulses



NOTICE

If interference can be anticipated on the signal cables or if the sensor cables are long, we recommend you use encoders with differential signals. Depending on the sensor, terminating resistors should be used to improve the quality of the signal (see sensor's data sheet).

- ▶ With Hiperface encoders, the Sin- Cos track is recorded and monitored via an adapter (see [Adapters for encoders](#) [📖 29]).
- ▶ Track S can be used:
 - To connect an encoder's error output.
 - To monitor voltages between 0 V and 30 V for a permitted upper and lower limit. For example, the encoder's supply voltage can be monitored.
- ▶ The maximum frequency of the used encoders must be entered for a complete configuration.
- ▶ Pay attention to the values in the technical details.

4.6.1

Output signals

Output signals TTL, HTL

Single ended

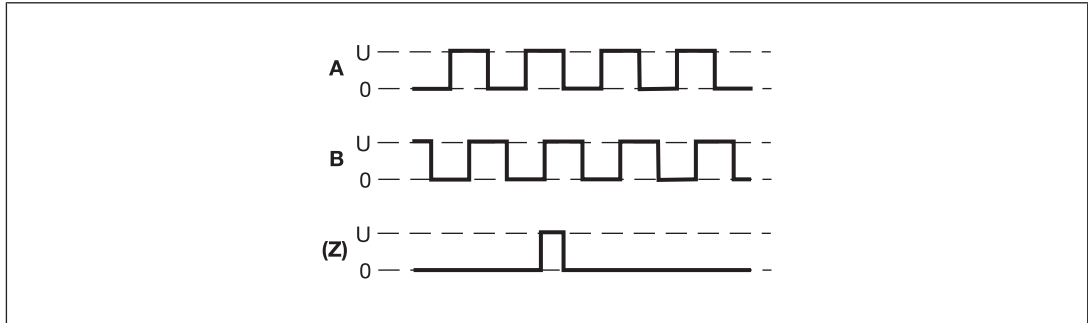

Differential

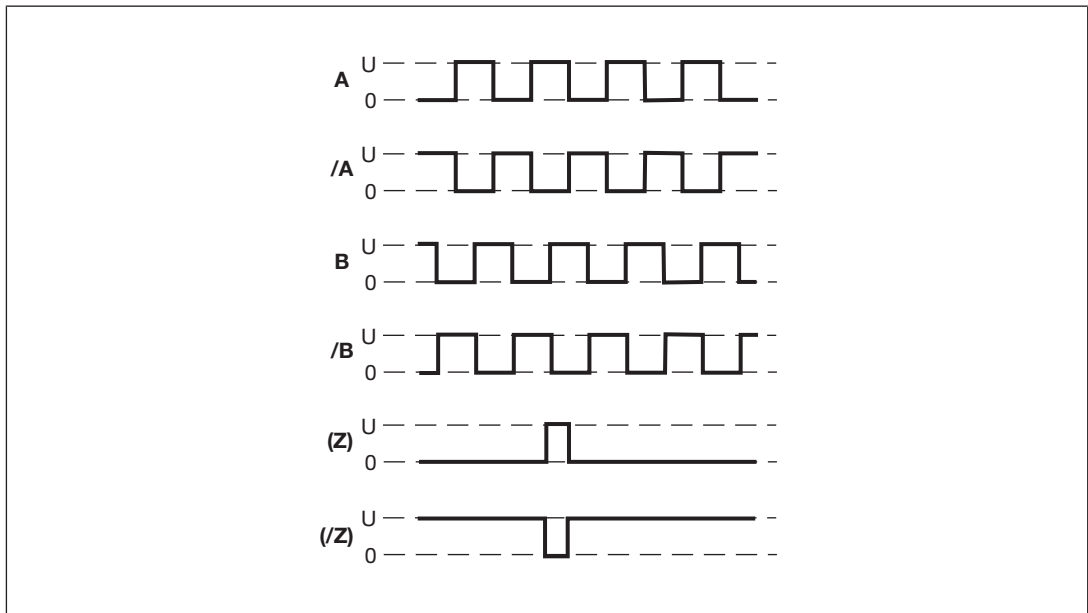

Output signals Sin/Cos (1 Vss)

Single ended with reference track (e.g. Hiperface ®)

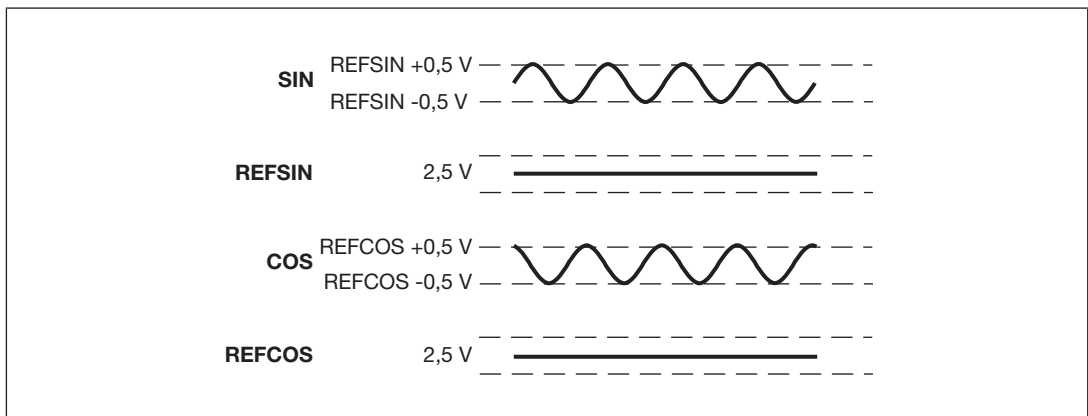

Differential with/without Z index (e.g. Heidenhain 1 Vss)

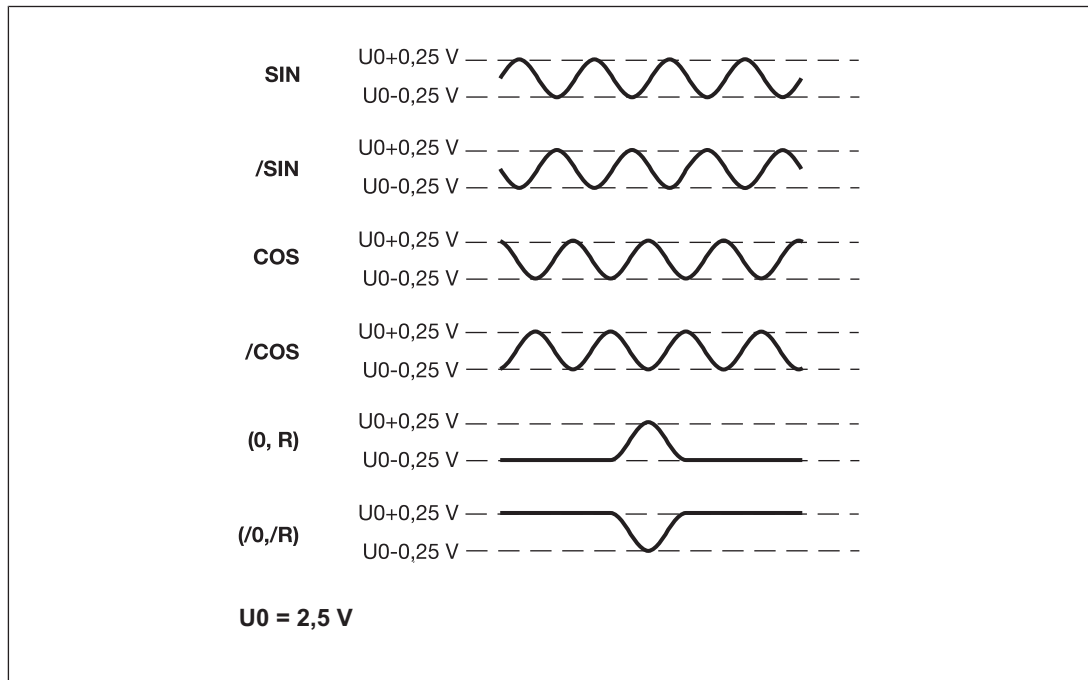

4.6.2 Adapters for encoders

The adapter records the data between the encoder and the drive and makes it available to the PNOZ m EF 1MM via the Mini-IO socket.

Pilz supplies complete adapters as well as ready-made cable with Mini-IO connector, which can be used when making your own adapter. The range of products in this area is constantly being expanded. Please contact us about the range of adapters that is currently available.

5 Installation

5.1 General installation guidelines

- ▶ The unit should be installed in a control cabinet with a protection type of at least IP54.
- ▶ Install the system vertically on to a horizontal mounting rail. The venting slots must face upward and downward. Other mounting positions could damage the safety system.
- ▶ Use the locking elements on the rear of the unit to attach it to a mounting rail.
- ▶ In environments exposed to heavy vibration, the unit should be secured using a fixing element (e.g. retaining bracket or end angle).
- ▶ Open the locking slide before lifting the unit from the mounting rail.
- ▶ To comply with EMC requirements, the mounting rail must have a low impedance connection to the control cabinet housing.
- ▶ The ambient temperature in the control cabinet must not exceed the figure stated in the technical details. otherwise air conditioning may be required.
- ▶ The unit may be exposed to various types of acceleration during operation. Please note the values stated in the technical details for vibration and shock stress. The acceleration values do not apply when mechanical resonances occur. so the whole system should be subjected to extensive testing.
- ▶ For the unit to work properly, it must not be constantly exposed to heavy vibration.



NOTICE

Damage due to electrostatic discharge!

Electrostatic discharge can damage components. Ensure against discharge before touching the product, e.g. by touching an earthed, conductive surface or by wearing an earthed armband.

5.2 Dimensions in mm

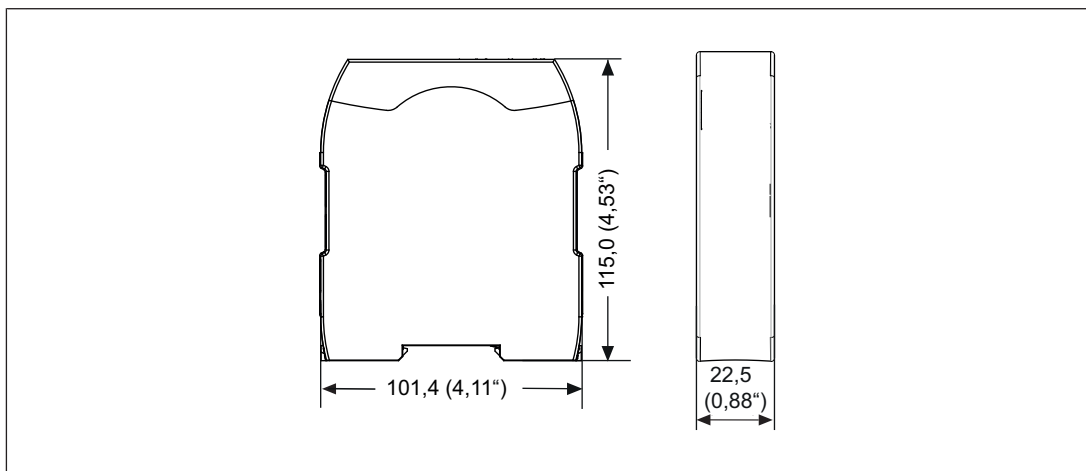

5.3 **Connect the base unit and expansion modules**

Connect the base unit and the expansion module as described in the operating instructions for the base units.

- ▶ Connect the black/yellow terminator to the expansion module.
- ▶ Install the expansion module in the position in which it is configured in the PNOZmulti Configurator.

The position of the expansion modules is defined in the PNOZmulti Configurator. The expansion modules are connected to the left or right of the base unit, depending on the type.

Please refer to the document "PNOZmulti System Expansion" for details of the number of modules that can be connected to the base unit and the module types.

6 Commissioning

6.1 Wiring

The wiring is defined in the circuit diagram of the PNOZmulti Configurator.

Please note:

- ▶ Information given in the [Technical details \[45\]](#) must be followed.
- ▶ The position of the expansion module is specified in the Hardware configuration of the PNOZmulti Configurator.
- ▶ Use copper wiring with a temperature stability of 75 °C.
- ▶ The power supplies for the safety system and sensors must comply with the regulations for low voltages with safe isolation.
- ▶ The cable used to connect the encoders and proximity switches must be shielded (see connection diagrams in the chapter entitled "EMC-compliant wiring").
- ▶ The shield may only be connected to earth at a single point.
- ▶ Earth loops should be avoided.
- ▶ If possible, the connections for the various earth potentials (GND, A2) should not be connected on the PNOZ m EF 1MM but should be connected directly to the GNDs on the connected units. otherwise noise susceptibility may be increased significantly (conductor loops are not permitted).



CAUTION!

Only connect and disconnect the expansion module when the supply voltage is switched off.

6.2 Pin assignment of Mini-IO socket

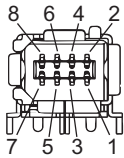
Mini-IO socket 8-pole	PIN	Track
	1	S
	2	GND
	3	Z
	4	A
	5	/A
	6	/Z
	7	B
	8	/B

6.3 Connection of proximity switches

The following proximity switch combinations can be connected:

- ▶ A: pnp, B: pnp
- ▶ A: npn, B: npn
- ▶ A: pnp, B: npn
- ▶ A: npn, B: pnp

When connecting proximity switches please note:

- ▶ Proximity switches can be connected to
 - terminals A12, B12, GND for axis 1
 - or
 - tracks A, B and GND of the Mini-IO socket (X12 for axis 1).
- ▶ Track S (S12) should be used to monitor the supply voltage (see drawing). A permitted voltage range can be entered in the menu.
- ▶ Connect the proximity switch to 24 VDC of the power supply.
- ▶ When connecting the proximity switches, please refer to the chapter entitled "EMC-compliant wiring".
- ▶ Invalid signals may occur with long cable lengths. In this case we recommend that you connect a resistor between the signal lines, as shown in the diagrams.
- ▶ Connection of the proximity switches may only be performed in three-wire technology and not in two-wire technology.
- ▶ Special features for proximity switches with reduced diagnostics:
 - A: pnp, B: pnp
 - It is permitted that both proximity switches are energised simultaneously.
 - The safety level is reduced.
 - The cables for connecting the proximity switches must be laid separately.
 - The supply voltage of the proximity switches must be monitored (e.g. via track S).

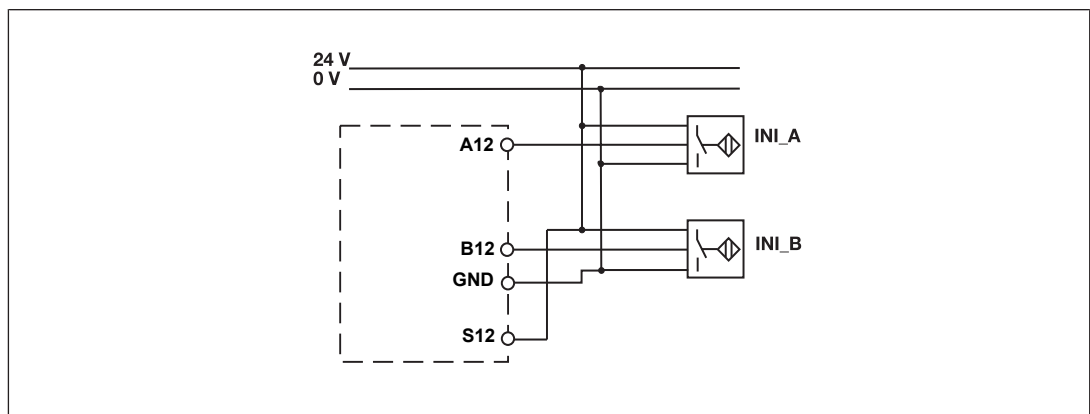

pnp proximity switch with resistor R = 10 kOhm

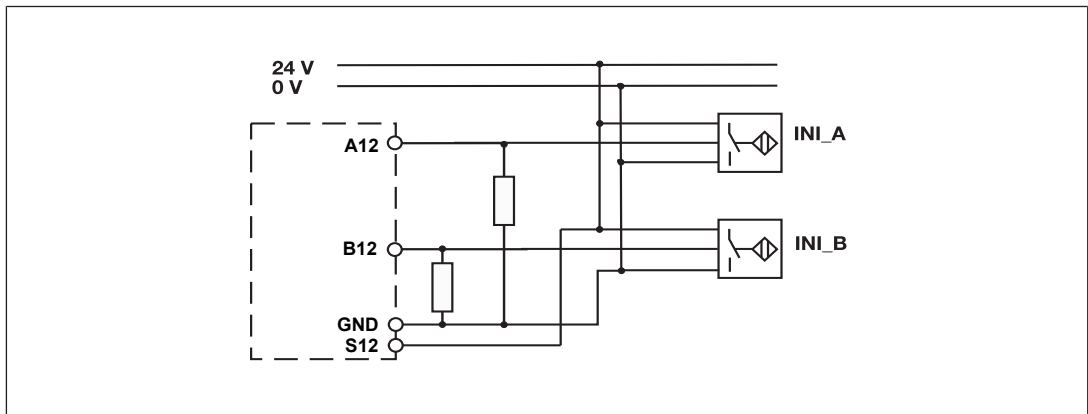

npn proximity switch with resistor R = 47 kOhm

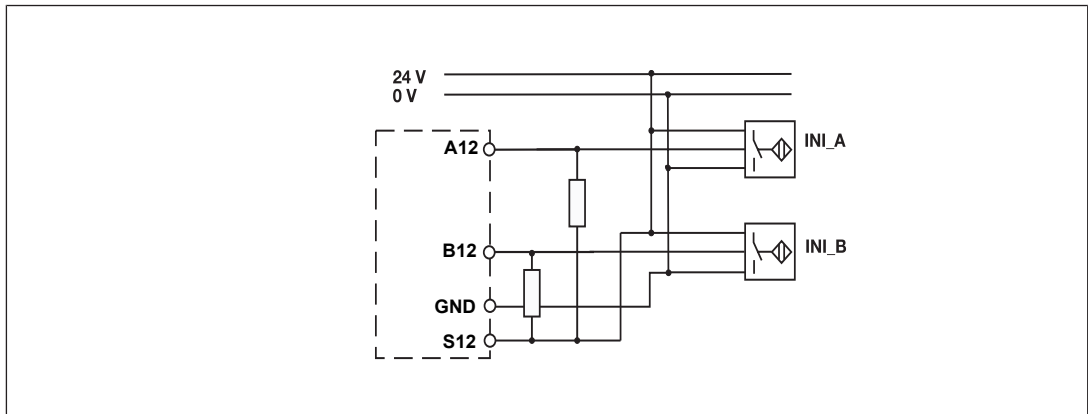

6.4 Connection of an encoder

Proceed as follows when connecting the encoder:

- ▶ The encoder can be connected via an adapter (e.g. MM A Mini-IO-CAB99) or directly to the PNOZ m EF 1MM.
- ▶ Use only shielded cables for all connections. Please refer to the chapter entitled "EMC-compliant wiring".
- ▶ Always connect GND on the encoder to GND on the Mini-IO connector.
- ▶ If the encoder signals are not terminated with 120 Ohm in the frequency converter, the encoder signals must be terminated with $Z_0 = 120 \text{ Ohm}$ between A and /A, B and /B, Z and /Z.
- ▶ Please refer to the information provided by the encoder manufacturer with regard to the recommended max. cable length when taking into consideration
 - Output frequency
 - Supply voltage
 - Operating temperature
 - Existing interference

When calculating the maximum cable length, remember that the length of the adapter cable must also be taken into account.



CAUTION!

Communication errors may occur if the adapter cable is too long or there are any external sources of interference. Use an adapter cable that's less than 5 m in length. Lay the adapter cable separately from any potential sources of interference, such as drive cables leading to the motor, for example.

6.4.1 Connect encoder

Encoder types:

- ▶ TTL single ended
- ▶ HTL single ended

Please note:

- ▶ Tracks /A, /B, Z and /Z must remain free

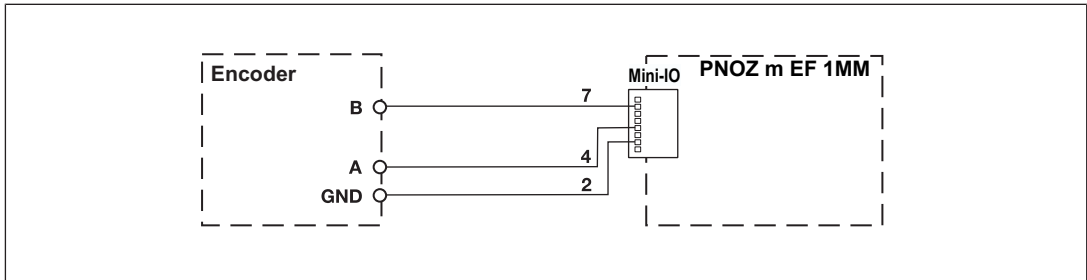

Encoder types:

- ▶ TTL Differential
- ▶ HTL differential
- ▶ sin/cos 1 V_{ss}
- ▶ Hiperface

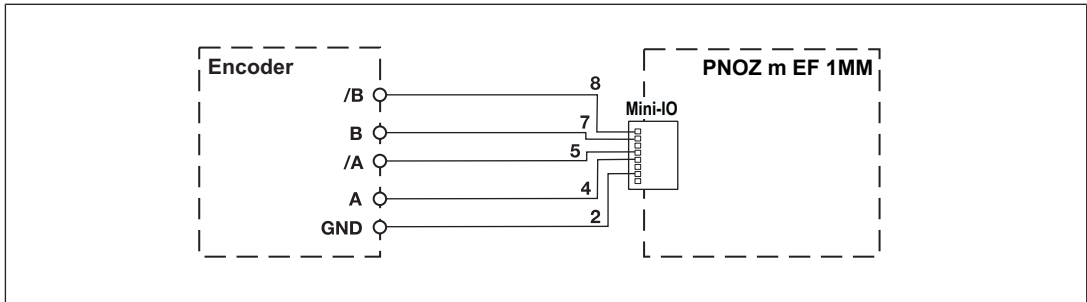

6.4.2 Connect encoder with Z index

Encoder types:

- ▶ TTL single ended Z Index
- ▶ HTL single ended Z Index

Please note:

- ▶ Tracks /A, /B and /Z must remain free

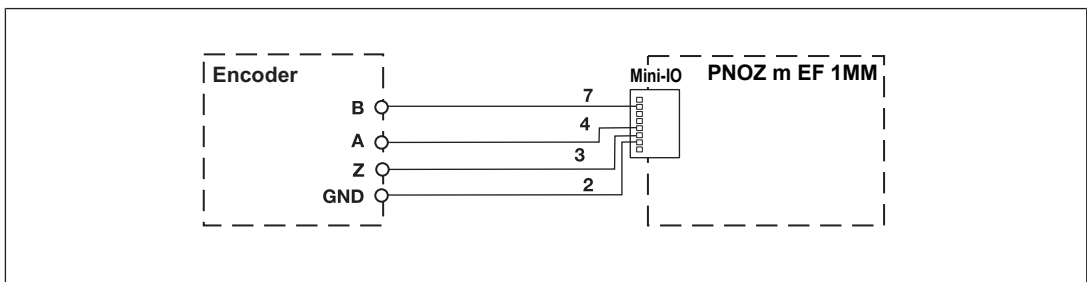

Encoder types:

- ▶ TTL differential + Z Index
- ▶ HTL differential + Z Index
- ▶ sin/cos 1 Vss Z Index

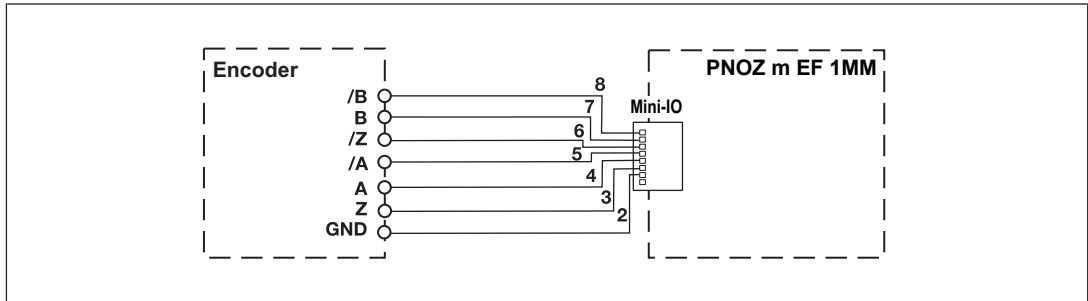

6.4.3 Connect encoder via an adapter

The adapter (see [Accessories \[61\]](#)) is connected between the encoder and the drive. The output on the adapter is connected to the Mini-IO socket on the PNOZ m EF 1MM.

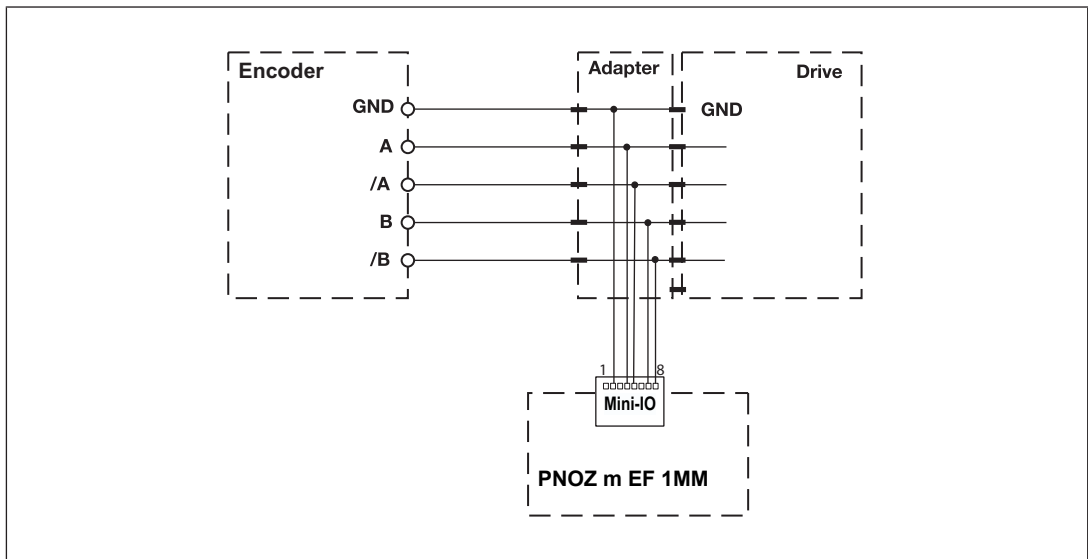

6.5 Connection of proximity switch and encoder

When connecting the encoders and proximity switches, please refer to the chapter entitled "EMC-compliant wiring".



INFORMATION

The following diagrams are principle connection diagrams. For better clarity, the shielding and supply voltage are not shown.

Sensor types:

- ▶ Configuration: HTL single Z Freq. Ini pnp
 - HTL single ended (A,B) + Ini pnp (Z)

- HTL single ended (A,B) + HTL differential (A as Z)
- HTL single ended (A,B) + HTL single ended (A as Z)
- ▶ Configuration: TTL single Z Freq. Ini pnp
 - TTL single ended (A,B) + Ini pnp (Z)
 - TTL single ended (A,B) + HTL differential (A as Z)
 - TTL single ended (A,B) + HTL single ended (A as Z)

Please note:

Tracks /A, /B and /Z must remain free.

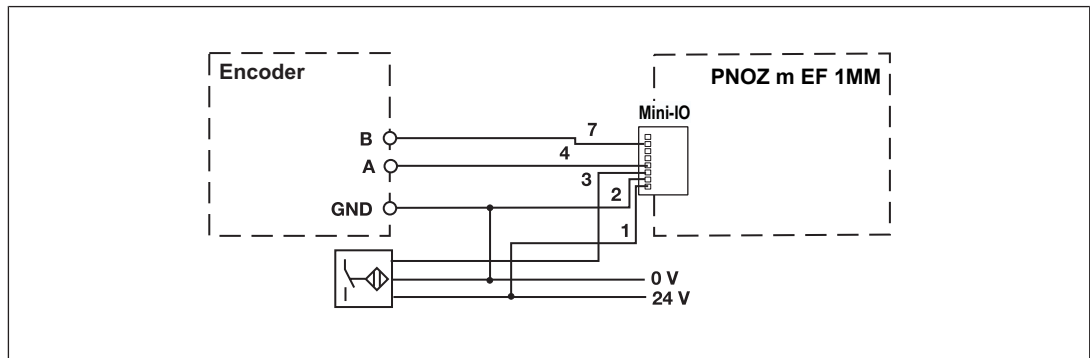

Sensor types:

- ▶ Configuration: TTL differential Z Freq. Ini pnp
 - TTL differential (A,/A,B,/B) + Ini pnp (Z)
 - TTL differential (A,/A,B,/B) + HTL differential (A as Z)
 - TTL differential (A,/A,B,/B) + HTL single ended (A as Z)
- ▶ Configuration: HTL differential Z Freq. Ini pnp
 - HTL differential (A,/A,B,/B) + Ini pnp (Z)
 - HTL differential (A,/A,B,/B) + HTL differential (A as Z)
 - HTL differential (A,/A,B,/B) + HTL single ended (A as Z)
- ▶ Configuration: sin/cos 1 Vss Z Freq. Ini pnp
 - sin/cos 1 Vss (A,/A,B,/B) + Ini pnp (Z)
 - sin/cos 1 Vss (A,/A,B,/B) + HTL differential (A as Z)
 - sin/cos 1 Vss (A,/A,B,/B) + HTL single ended (A as Z)
- ▶ Configuration: Hiperface Z Freq. Ini pnp
 - Hiperface (A,/A,B,/B) + Ini pnp (Z)
 - Hiperface (A,/A,B,/B) + HTL differential (A as Z)
 - Hiperface (A,/A,B,/B) + HTL single ended (A as Z)

Please note:

Track /Z must remain free!!

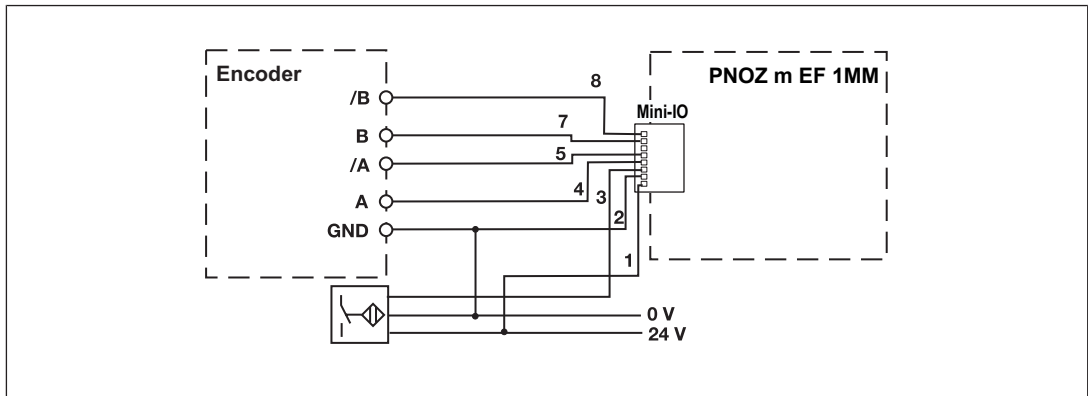

6.6 EMC-compliant wiring

EMC-compliant wiring for connecting an encoder

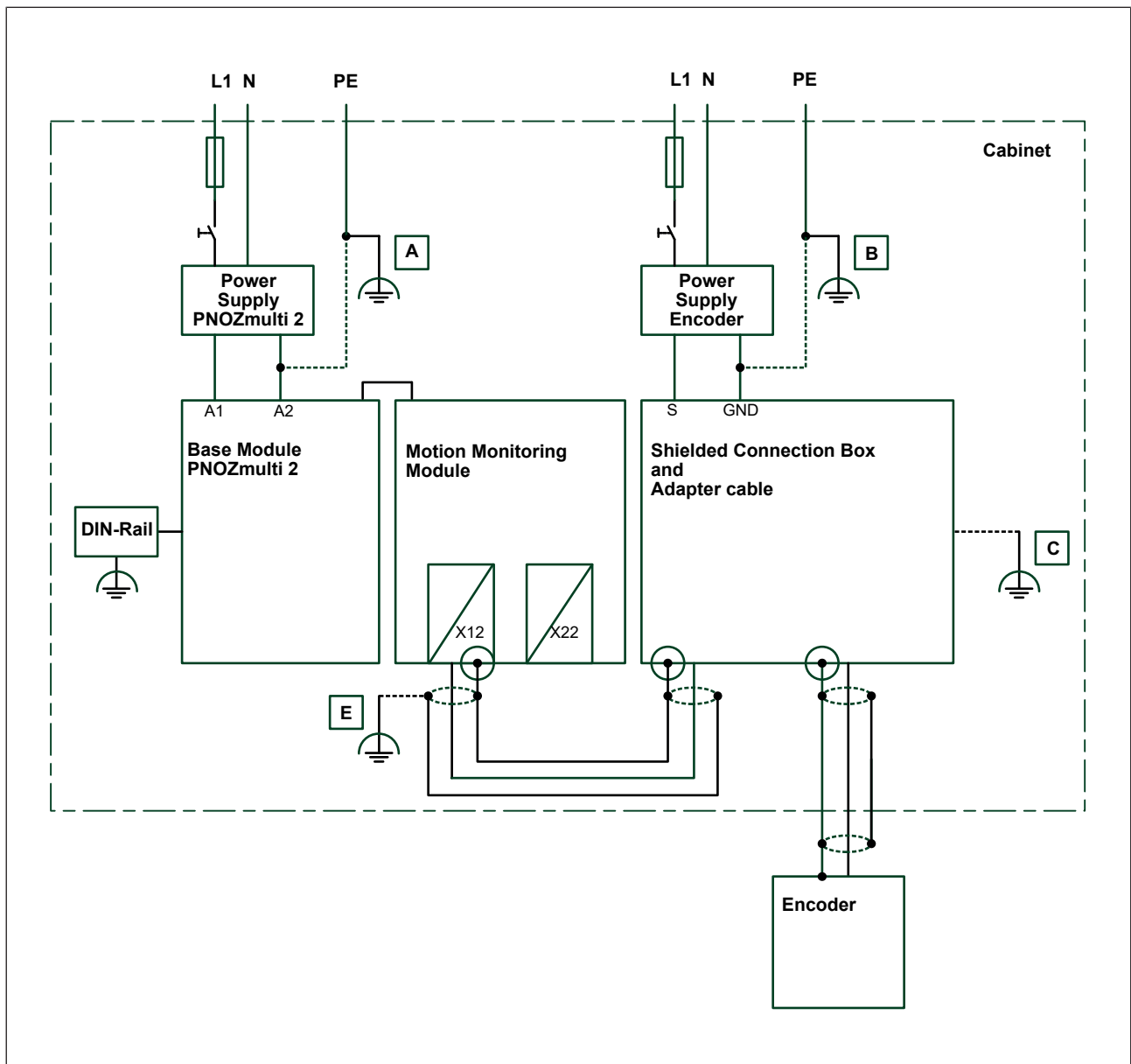

To avoid EMC interference we recommend that the shield on the sensor cable is connected to earth at **C** or **E**. However, depending on the application, it may be helpful to establish the connection to functional earth at another point (in this case **A** or **B**).

Conductor loops outside the shield must be avoided.

If a shielded junction box is not used, the shield must run continuously from the sensor to the evaluation device.

EMC-compliant wiring for connecting an encoder with drive

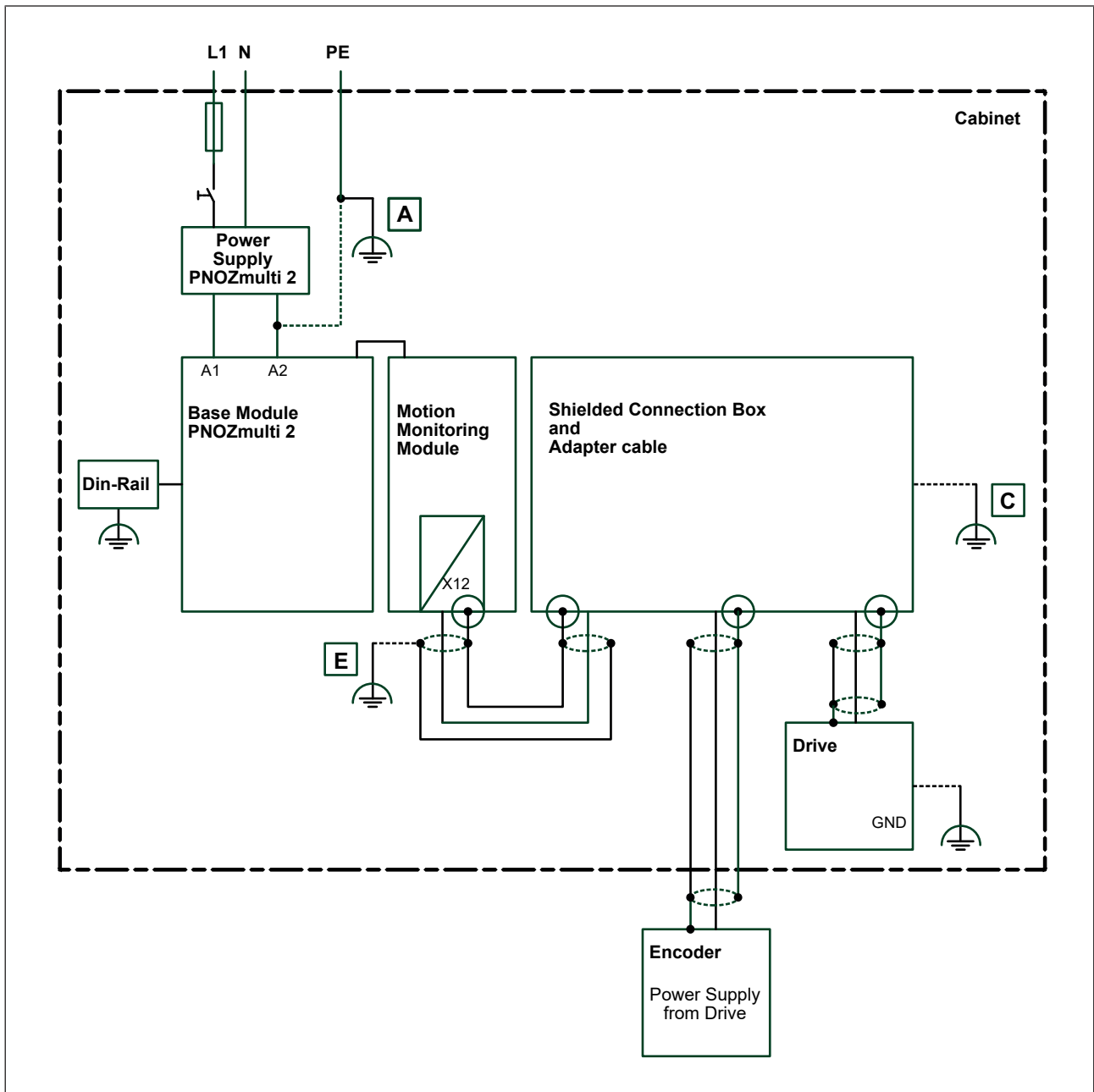

To avoid EMC interference we recommend that the shield on the sensor cable is connected to earth at **C** or **E**. However, depending on the application, it may be helpful to establish the connection to functional earth at another point (in this case **A**).

Conductor loops outside the shield must be avoided.
 If a shielded junction box is not used, the shield must run continuously from the sensor to the evaluation device.

EMC-compliant wiring for connecting 2 proximity switches

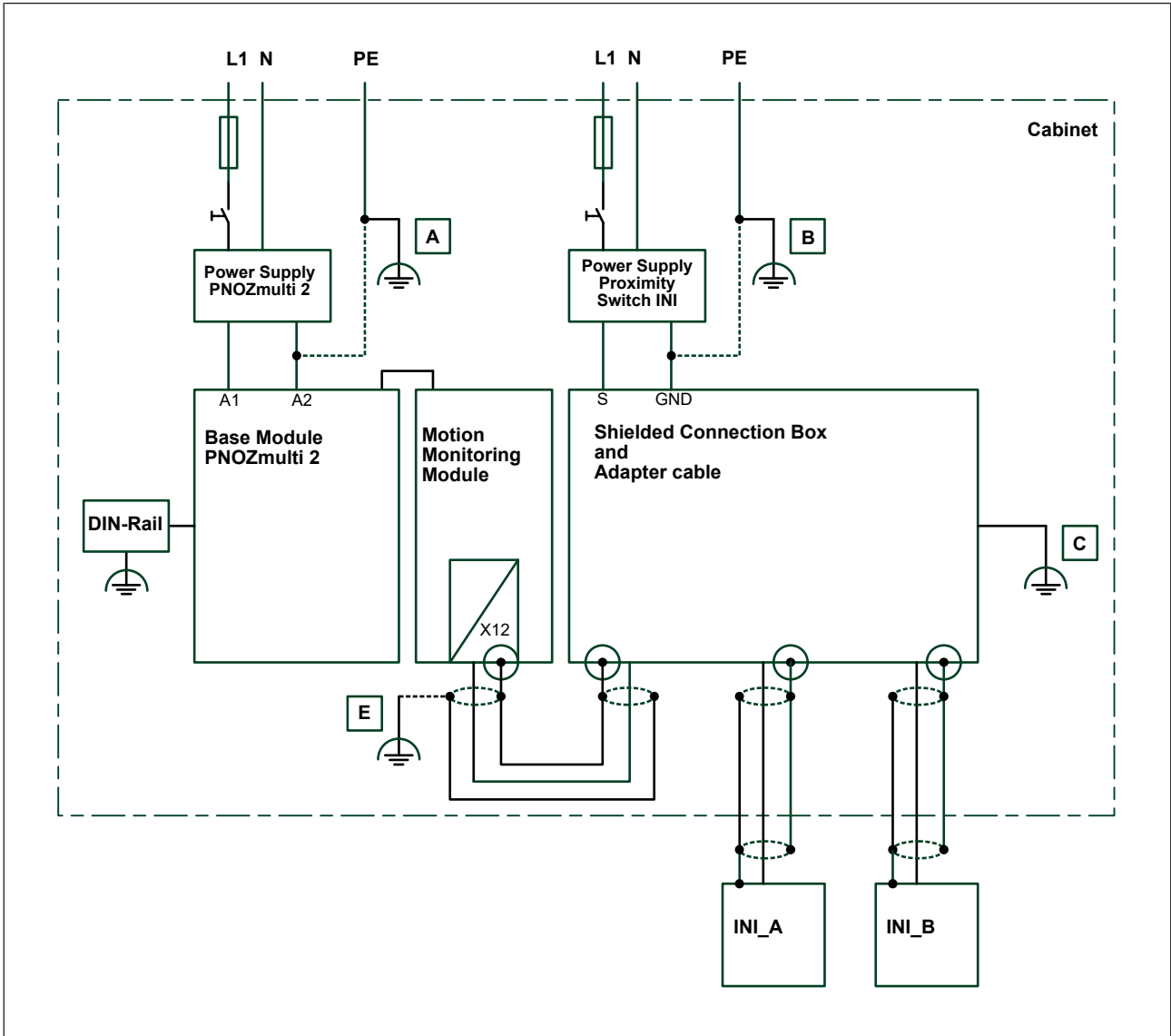

To avoid EMC interference we recommend that the shield on the sensor cable is connected to earth at **C** or **E**. However, depending on the application, it may be helpful to establish the connection to functional earth at another point (in this case **A** or **B**).

Conductor loops outside the shield must be avoided.
 If a shielded junction box is not used, the shield must run continuously from the sensor to the evaluation device.

EMC-compliant wiring for connecting an encoder and a proximity switch

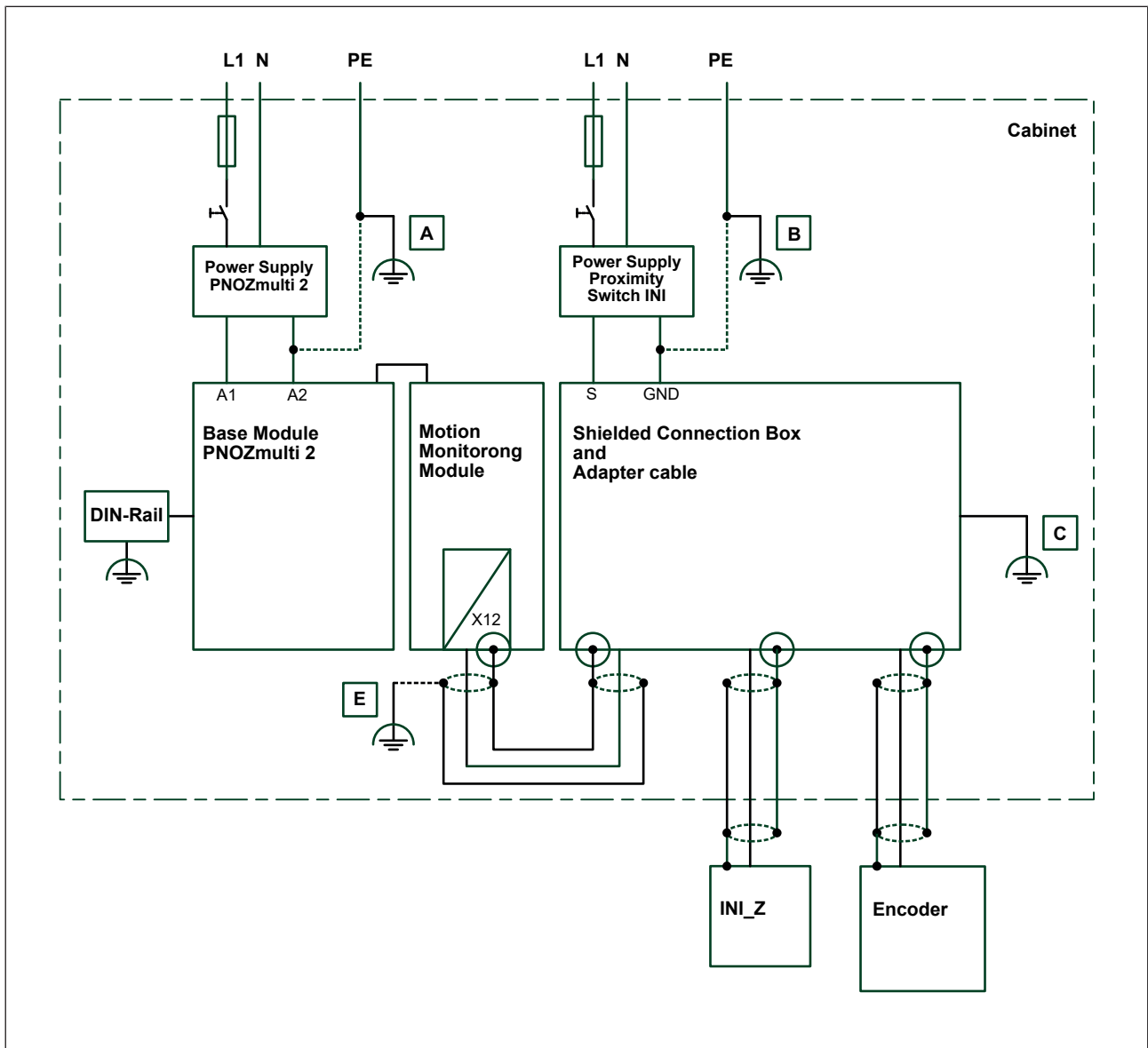

To avoid EMC interference we recommend that the shield on the sensor cable is connected to earth at **C** or **E**. However, depending on the application, it may be helpful to establish the connection to functional earth at another point (in this case **A** or **B**).

Conductor loops outside the shield must be avoided.

If a shielded junction box is not used, the shield must run continuously from the sensor to the evaluation device.

6.7 Download modified project to the PNOZmulti system

As soon as an additional expansion module has been connected to the system, the project must be amended in the PNOZmulti Configurator and downloaded back into the base unit. Proceed as described in the operating manual for the base unit.



NOTICE



For the commissioning and after every user program change, you must check whether the safety devices are functioning correctly.

7 Operation





















The PNOZmulti system is ready for operation when the "POWER" and "RUN" LEDs on the base unit are lit continuously.

7.1 LED indicators

Legend

-  LED on
-  LED flashes

Please note that these displays may also appear in combination.

LED					Fault
Power	Run	Diag	Fault	Axis 1	
					No supply voltage
					Expansion module PNOZ m EF 1MM is in a STOP condition.
					Expansion module PNOZ m EF 1MM is running without error, no axis is active.
					Axis is not yet ready.
					Axis is configured and is running.
					Internal error on the expansion module PNOZ m EF 1MM or on the overall system. Expansion module is in a safe condition.
					External error on the expansion module PNOZ m EF 1MM or on the overall system. Expansion module is in a safe condition.
					Implausible sensor signal
					Implausible sensor signal or internal error

7.2 Behaviour with implausible sensor signals

Implausible sensor signals (e.g. frequency difference between Track A and B or the ratio of AB to Z is not correct) do not lead to an FS stop of the PNOZmulti system.

However, the error is displayed through the LEDs at the device and through an error stack entry. All the safety functions that refer to the Motion Monitoring area will be deactivated. The global reset can be used to reactivate the safety function when feasible signals are connected.

Depending on the case of an error and the applied frequency, the detection of an implausible sensor signal may take some time.

8 Technical details

General	
Certifications	CE, EAC (Eurasian), KOSHA, TÜV, cULus Listed
Application range	Failsafe
Module's device code	00E3h
Electrical data	
Supply voltage	
for	Module supply
internal	Via base unit
Voltage	24 V
Kind	DC
Current consumption	90 mA
Power consumption	2 W
Max. power dissipation of module	2,2 W
Status indicator	LED
Proximity switch input	
Number of inputs	2
Input signal level	
Signal level at "1"	11 - 30 V
Signal level at "0"	0,0 - 3,0 V
Input resistance	22 kOhm
Input's frequency range	0 - 5 kHz
Configurable monitoring frequency	
Without hysteresis	0,1 Hz - 5 kHz
Incremental encoder input	
Number of inputs	1
Connection type	Mini-IO female connector, 8-pin
Input signal level	0,5 - 30 V_{ss}
Phase position for the differential signals A, /A and B, /B	90° ±30°
Overload protection	-50 - 65 V
Input resistance	20 kOhm
Input's frequency range	0 - 500 kHz
Configurable monitoring frequency	
Without hysteresis	0,1 Hz - 500 kHz
Inputs	
Potential isolation	yes
Times	
Reaction time after limit value is exceeded	1/f_ist + 16 ms

Environmental data

Ambient temperature		
In accordance with the standard		EN 60068-2-14
Temperature range		0 - 60 °C
Forced convection in control cabinet off		55 °C
Storage temperature		
In accordance with the standard		EN 60068-2-1/-2
Temperature range		-25 - 70 °C
Climatic suitability		
In accordance with the standard		EN 60068-2-30, EN 60068-2-78
Condensation during operation		Not permitted
Max. operating height above sea level		2000 m
EMC		EN 61131-2
Vibration		
In accordance with the standard		EN 60068-2-6
Frequency		5 - 150 Hz
Acceleration		1g
Shock stress		
In accordance with the standard		EN 60068-2-27
Acceleration		15g
Duration		11 ms
Airgap creepage		
In accordance with the standard		EN 61131-2
Overvoltage category		II
Pollution degree		2
Protection type		
In accordance with the standard		EN 60529
Housing		IP20
Terminals		IP20
Mounting area (e.g. control cabinet)		IP54

Potential isolation

Potential isolation between		Sensor and system voltage
Type of potential isolation		Functional insulation
Rated insulation voltage		30 V
Rated surge voltage		2500 V

Mechanical data

Mounting position		horizontally on mounting rail
DIN rail		
Top hat rail		35 x 7,5 EN 50022
Recess width		27 mm
Material		
Bottom		PC
Front		PC
Top		PC
Connection type		Spring-loaded terminal, screw terminal

Mechanical data	
Mounting type	plug-in
Conductor cross section with screw terminals	
1 core flexible	0,25 - 2,5 mm ² , 24 - 12 AWG
2 core with the same cross section, flexible without crimp connectors or with TWIN crimp connectors	0,2 - 1,5 mm ² , 24 - 16 AWG
Torque setting with screw terminals	0,5 Nm
Conductor cross section with spring-loaded terminals: Flexible with/without crimp connector	0,2 - 2,5 mm ² , 24 - 12 AWG
Spring-loaded terminals: Terminal points per connection	2
Stripping length with spring-loaded terminals	9 mm
Dimensions	
Height	101,4 mm
Width	22,5 mm
Depth	111 mm
Weight	90 g

Where standards are undated, the 2018-09 latest editions shall apply.

8.1 Safety characteristic data

Operating mode	EN ISO 13849-1: 2015 PL	EN ISO 13849-1: 2015 Category	EN IEC 62061 SIL CL	EN IEC 62061 PFH _D [1/h]	IEC 61511 SIL	IEC 61511 PFD	EN ISO 13849-1: 2015 T _M [year]
Monitoring 1 encoder	PL d	Cat. 2	SIL CL 2	1,80E-08	SIL 2	1,58E-03	20
Monitoring 2 encoder	PL e	Cat. 3	SIL CL 3	1,01E-09	SIL 3	8,41E-05	20
Monitoring safe encoder	PL e	Cat. 4	SIL CL 3	2,35E-09	SIL 3	2,04E-04	20
Logic	PL e	Cat. 4	SIL CL 3	3,37E-10	SIL 3	2,88E-05	20

All the units used within a safety function must be considered when calculating the safety characteristic data.



INFORMATION

A safety function's SIL/PL values are **not** identical to the SIL/PL values of the units that are used and may be different. We recommend that you use the PAScal software tool to calculate the safety function's SIL/PL values.

9 Supplementary data

9.1 Categories

9.1.1 Safety level

The maximum achievable safety level depends, among other things, on the sensor, the wiring and the operating mode of the PNOZ m EF 1MM.



INFORMATION

The safety-related characteristic data of the PNOZ m EF 1MM and all other devices that are used must be taken into account when calculating the safety level. We recommend that you use the PAScal software tool to calculate the safety function's SIL/PL values.

The safety assessments below only consider the subsystems *Sensor* and PNOZ m EF 1MM. The *Actuator* subsystem depends on the application and must also be considered in the overall assessment.

Information on the safety-related characteristic data for the subsystems *Sensor* and PNOZ m EF 1MM

Example:

Sensor subsystem			Subsystem PNOZ m EF 1MM	
Category	MTTFd	DC	Operating mode	PFH [1/h]
2	Manufacturer-specific	90 %	Monitoring 1 sensor	1,83E-08

The values for **Category** and **DC** can be set for the sensor subsystem, bearing in mind the restrictions stated in the respective chapter. The MTTFd value must be stated by the sensor manufacturer.

The values for **DC** refer to the standard EN 61508.

Assuming that all faults are dangerous, MTTF = MTTFd can be set.

The characteristic value MTTF is a property of the sensor, which may only be stated by the manufacturer.

Forced dynamisation:

When monitoring sensors with square output signals (TTL, HTL) or safe sensors, the axis must be moved within 8 hours so that the signal changes on all the connected tracks.

Key:

SRP/CS = Safety-related part of a control system (EN 13849-1, Tab. 2)

9.1.2 Safety functions

The following safe monitoring functions are available:

- ▶ Safe speed monitoring (SSM)
- ▶ Safe speed range monitoring (SSR-M)
- ▶ Safe direction monitoring (SDI-M)
- ▶ Safe operating stop monitoring (SOS-M)
- ▶ Safe stop 1 monitoring (SS1-M)
- ▶ Safe stop 2 monitoring (SS2-M)
- ▶ Safely limited acceleration monitoring (SLA-M)
- ▶ Safely limited acceleration range monitoring (SAR-M)

The safety functions of the PNOZ m EF 1MM are monitoring functions, whereby a safe output signal is used to show if defined limit values are exceeded.

The reaction function that takes place (e.g. shutting down the drive, activating a mechanical brake) when exceeded limit values are detected during the normal operation of the safety function must be defined and implemented by the machine/plant developer and does not form part of the PNOZ m EF 1MM.

The monitoring function of the PNOZ m EF 1MM can be used to implement safety functions defined in the standard EN 61800-5-2 for Adjustable speed electrical power drive systems.

Safety functions in accordance with EN 61800-5-2	Implemented with monitoring function of the PNOZ m EF 1MM
Safe Operating Stop (SOS)	Safe operating stop monitoring (SOS-M)
Safe Speed Range (SSR)	Safe speed range monitoring (SSR-M)
Safe Direction (SDI)	Safe direction monitoring (SDI-M)
Safe Speed Monitoring (SSM)	Safe speed monitoring (SSM)
Safe Stop 1 (SS1)	Safe stop 1 monitoring (SS1-M)
Safe Stop 2 (Safe stop 2, SS2)	Safe stop 2 monitoring (SS2-M)
Safely Limited Acceleration (Safely Limited Acceleration, SLA)	Safely limited acceleration monitoring (SLA-M)
Safely Acceleration Range Monitoring (Safely Acceleration Range Monitoring, SAR)	Safely limited acceleration range monitoring (SAR-M)

9.1.3 Safety-related characteristic data for operation with non-safety-related encoder without additional requirements

9.1.3.1 Permitted sensor types and output signals

Permitted encoder types:

- ▶ Rotary non-safety-related encoders
- ▶ Linear non-safety-related encoders

Permitted output signals:

- ▶ Square output signals TTL, single ended
- ▶ Square output signals TTL, differential
- ▶ Square output signals HTL, single ended
- ▶ Square output signals HTL, differential
- ▶ Sin/Cos output signals 1Vss, reference voltage
- ▶ Sin/Cos output signals 1Vss, differential

9.1.3.2 Safety-related architecture

To calculate the safety function you will need the following data for the "sensor" subsystem and the subsystem PNOZ m EF 1MM:

Sensor			Subsystem PNOZ m EF 1MM	
Category	MTTFd	DC	Operating mode	PFH (1/h)
1*	Manufacturer-specific	0 %	Monitoring 1 sensor	1,83E-08

The values for **DC** refer to the standard EN 61508.

*In accordance with EN ISO 13849-1, Category 1 is only met if the sensor is a "well-tried component".

9.1.3.3 Achievable safety level

Monitoring function	PL of EN ISO 13849-1: 2015	SIL CL in accordance with EN IEC 62061
SOS-M	PL c (Cat.1)	-
SSR-M		
SDI-M		
SSM		
SS1-M		
SS2-M		
SLA-M		
SAR-M		

9.1.4 Safety-related characteristic data for operation with non-safety-related encoder with mechanical fault exclusion

In accordance with EN 61800-5-2: 2007, Table D.16 (Motion and position feedback sensors), fault exclusions are permitted for faults in the mechanical connection between the sensor and motor.

9.1.4.1 Permitted sensor types and output signals

Permitted encoder types:

- ▶ Rotary non-safety-related encoders

Permitted output signals:

- ▶ Sin/Cos output signals 1Vss, reference voltage
- ▶ Sin/Cos output signals 1Vss, differential



NOTICE

The signal tracks Cos and Sin must be generated independently. This means that the sine and cosine signals in the encoder must be conducted in independent channels, from the optics to the interface.

The two signal tracks must not be generated by a common processor.

One signal may not be derived from the other signal via an electronic circuit.

9.1.4.2 Safety-related architecture

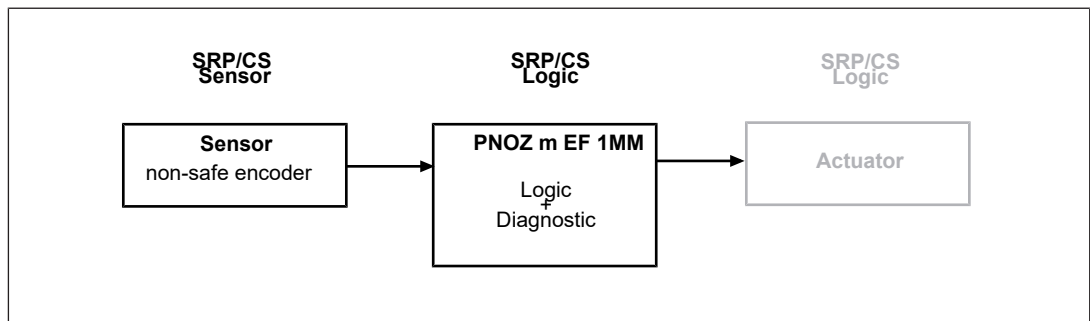

To calculate the safety function you will need the following data for the "sensor" subsystem and the subsystem "PNOZ m EF 1MM":

Sensor			Subsystem PNOZ m EF 1MM	
Category	MTTFd	DC	Operating mode	PFH (1/h)
2	Manufacturer-specific	90 %	Monitoring 1 sensor	1,83E-08

The values for **DC** refer to the standard EN 61508.

9.1.4.3 Achievable safety level

Monitoring function	PL of EN ISO 13849-1: 2015	SIL CL in accordance with EN IEC 62061
SOS-M	PL d (Cat.2)	2
SSR-M		
SDI-M		
SSM		
SS1-M		
SS2-M		
SLA-M		
SAR-M		

9.1.5 Safety-related characteristic data for operation with non-safety-related encoder with diagnostics via the drive controller

The detection of sensor errors (diagnostics for the sensor subsystem via the evaluation device) can be supplemented with a drive controller.

9.1.5.1 Permitted sensor types and output signals

Permitted sensor types:

- ▶ Rotary non-safety-related encoders
- ▶ Linear non-safety-related encoders

Permitted output signals:

- ▶ Square output signals TTL, single ended
- ▶ Square output signals TTL, differential
- ▶ Square output signals HTL, single ended
- ▶ Square output signals HTL, differential
- ▶ Sin/Cos output signals 1V_{ss}, reference voltage
- ▶ Sin/Cos output signals 1V_{ss}, differential

9.1.5.2 Requirements of the drive controller

- ▶ Parameters for the control loops and motor control must be set in such a way as to guarantee stable operation.
Drag error detection (see below) must be capable of operating in accordance with the requirements of the safety function.
- ▶ The motor must be operated with a current impressing control procedure, based on the rotor position (field-oriented control). If the analogue track signals are idle, field-oriented control will brake and/or stop the rotor.
- ▶ The drive controller must be in position control operating mode.
- ▶ If a maximum error variable is exceeded (set/true comparison) the drive controller must switch to a fault condition and stop the drive (drag error detection). The error reaction to drag error detection should be a controlled motor stop.

- ▶ Fault detection via the error variable with subsequent shutdown must meet the requirements of the safety function, with regard to reaction times for example.
- ▶ The drive controller must evaluate the same incremental/SinCos signals from the encoder for control as are processed by the safe evaluation device (important on encoders with combined analogue/digital interface).

9.1.5.3 Safety-related architecture

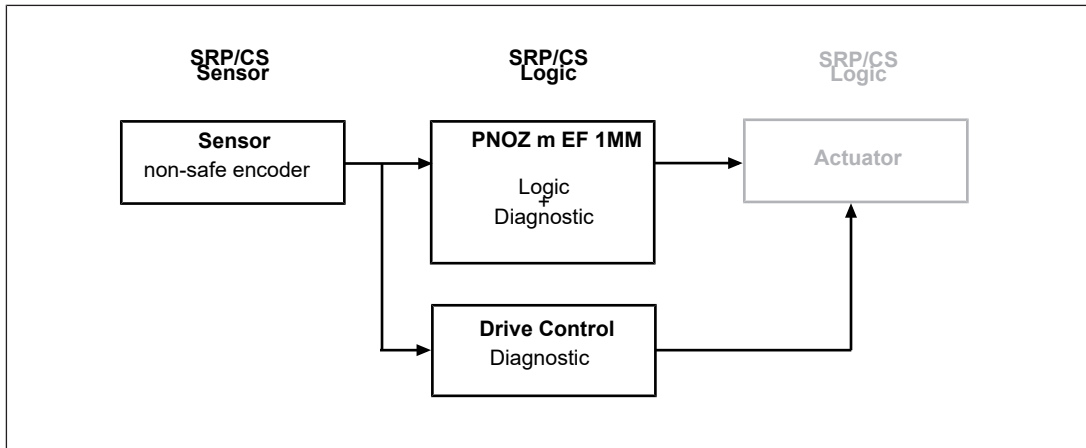

To calculate the safety function you will need the following data for the "sensor" subsystem and the subsystem "PNOZ m EF 1MM":

Sensor			Subsystem PNOZ m EF 1MM	
Category	MTTFd	DC	Operating mode	PFH (1/h)
2	Manufacturer-specific	90 %	Monitoring 1 sensor	1,83E-08

The values for **DC** refer to the standard EN 61508.

9.1.5.4 Achievable safety level

Monitoring function	PL of EN ISO 13849-1: 2015	SIL CL in accordance with EN IEC 62061
SOS-M	PL d (Cat.2)	2
SSR-M		
SDI-M		
SSM		
SS1-M		
SS2-M		
SLA-M		
SAR-M		

9.1.6 Safety-related characteristic data for operation with a safe encoder

Safe encoders are certified in accordance with EN 61508, EN 13849 and EN 62061. In order to achieve the safety level stated by the encoder, the safe evaluation device (PNOZ m EF 1MM) must normally detect designated errors. Details of the safe encoder's requirements of the evaluation device can be found in the user documentation for the safe encoder. The encoder and evaluation device must be compatible.

9.1.6.1 Permitted sensor types and output signals

Permitted encoder types:

- ▶ Rotary safety-related encoders
- ▶ Linear safety-related encoders

Permitted output signals:

- ▶ Sin/Cos output signals 1Vss, reference voltage
- ▶ Sin/Cos output signals 1Vss, differential

9.1.6.2 Safety-related architecture

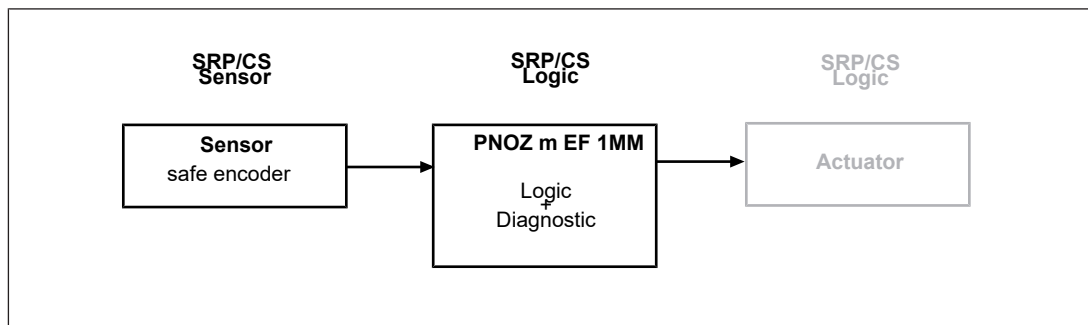

To calculate the safety function you will need the following data for the "sensor" subsystem and the subsystem "PNOZ m EF 1MM":

Sensor			Subsystem PNOZ m EF 1MM	
PL	SIL	PFH (1/h)	Operating mode	PFH (1/h)
See manufacturer			Monitoring Safe sensor	2,69E-09

9.1.6.3 Achievable safety level

Monitoring function	PL of EN ISO 13849-1: 2015	SIL CL in accordance with EN IEC 62061
SOS-M SSR-M SDI-M SSM SS1-M SS2-M SLA-M SAR-M	PL e (Cat.4)	3

9.1.7 Safety-related characteristic data for operation with a safe encoder with Z index

Safe encoders are certified in accordance with EN 61508, EN 13849 and EN 62061. In order to achieve the safety level stated by the encoder, the safe evaluation device (PNOZ m EF 1MM) must normally detect designated errors. Details of the safe encoder's requirements of the evaluation device can be found in the user documentation for the safe encoder. The encoder and evaluation device must be compatible.

9.1.7.1 Permitted sensor types and output signals

Permitted encoder types:

- ▶ Rotary safety-related encoders
- ▶ Linear safety-related encoders

Permitted output signals:

- ▶ Square output signals TTL, differential with Z index
- ▶ Square output signals HTL, differential with Z index
- ▶ Sin/Cos output signals 1Vss, reference voltage with Z index
- ▶ Sin/Cos output signals 1Vss, differential with Z index

9.1.7.2 Safety-related architecture

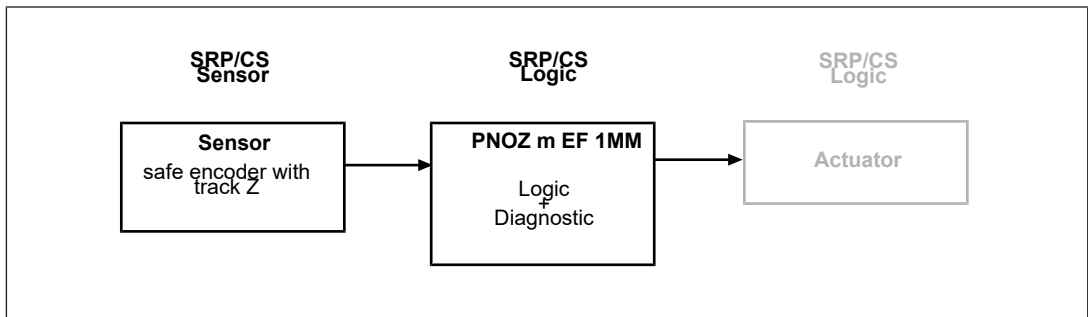

To calculate the safety function you will need the following data for the "sensor" subsystem and the subsystem "PNOZ m EF 1MM":

Sensor			Subsystem PNOZ m EF 1MM	
PL	SIL	PFH (1/h)	Operating mode	PFH (1/h)
See manufacturer			Monitoring 2 sensors	1,35E-09

9.1.7.3 Achievable safety level

Monitoring function	PL of EN ISO 13849-1: 2015	SIL CL in accordance with EN IEC 62061
SOS-M	PL e (Cat.4)	3
SSR-M		
SDI-M		
SSM		
SS1-M		
SS2-M		
SLA-M		
SAR-M		

9.1.8 Safety-related characteristic data for operation with non-safety-related encoder and proximity switch

The speed monitoring of the non-safety-related encoder can be verified via an additional reference sensor.

9.1.8.1 Permitted sensor types and output signals

Non-safety-related encoder

Permitted encoder types:

- ▶ Rotary non-safety-related encoders
- ▶ Linear non-safety-related encoders

Permitted output signals:

- ▶ Square output signals TTL, single ended
- ▶ Square output signals TTL, differential
- ▶ Square output signals HTL, single ended
- ▶ Square output signals HTL, differential
- ▶ Sin/Cos output signals 1Vss, reference voltage
- ▶ Sin/Cos output signals 1Vss, differential

Reference sensor

Permitted encoder types:

- ▶ Rotary non-safety-related encoders
- ▶ Linear non-safety-related encoders

- ▶ Inductive proximity switches

Permitted output signals:

- ▶ Square output signals HTL, single ended
- ▶ Square output signal 24 V, pnp

9.1.8.2 Safety-related architecture

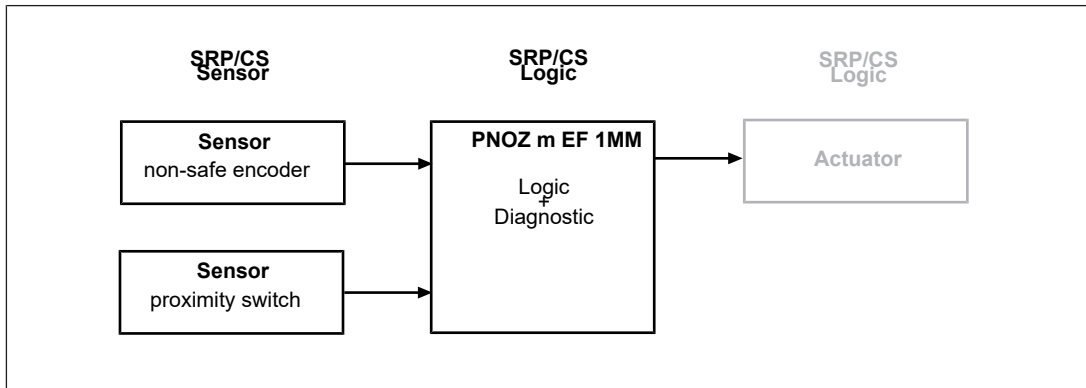

To calculate the safety function you will need the following data for the "sensor" subsystem and the subsystem PNOZ m EF 1MM:

Sensor			Subsystem PNOZ m EF 1MM	
Category	MTTFd	DC	Operating mode	PFH (1/h)
4	Manufacturer-specific	90 %	Monitoring 2 sensors	1,35E-09

In a worst case scenario, the sensor subsystem's characteristic value MTTFd is calculated from the inferior (lower) value of the two sensors.

The values for **DC** refer to the standard EN 61508.

9.1.8.3 Achievable safety level

Monitoring function	PL of EN ISO 13849-1: 2015	SIL CL in accordance with EN IEC 62061
SOS-M SDI-M SS2-M	PL c (Cat.1)	-
SSR-M SSM SS1-M SLA-M SAR-M	PL e (Cat.4)	3

Please note:

For the "sensor" subsystem, a minimum speed must be exceeded within forced dynamisation.

The minimum speed depends on the ratio of the frequency at tracks AB " f_{AB} " to the frequency at track Z " f_Z " in your configuration (see PNOZmulti Configurator **Element Motion Monitor**, value **Calculated Ratio AB/Z**) and is determined as follows:

- ▶ when **f_{AB}/f_Z Ratio** ≥ 1.0
 $f_Z = 10 \text{ mHz}$ or $f_{AB} = (f_{AB}/f_Z) \times 10 \text{ mHz}$
- ▶ when **f_{AB}/f_Z Ratio** < 1.0
 $f_{AB} = 10 \text{ mHz}$ or $f_Z = 10 \text{ mHz}/(f_{AB}/f_Z)$

At the very latest, a feasibility error will be detected when a tolerance expires. The tolerance level depends on the ratio of the frequency at tracks AB " f_{AB} " to the frequency at track Z " f_Z " in your configuration (**f_{AB}/f_Z Ratio** setting in the menu) and is calculated as follows:

- ▶ when **f_{AB}/f_Z Ratio** ≥ 1.0
 7.5 Z-pulses or $7.5 \times (f_{AB}/f_Z)$ AB-pulses
- ▶ when **f_{AB}/f_Z Ratio** < 1.0
 4.5 AB-pulses or $4.5/(f_{AB}/f_Z)$ Z-pulses

9.1.9 Safety-related characteristic data for operation with 2 proximity switches

9.1.9.1 Permitted sensor types and output signals

Non-safety-related sensor

Permitted sensor types:

- ▶ Inductive proximity switches

Permitted output circuits:

- ▶ pnp
- ▶ npn

9.1.9.2 Safety-related architecture

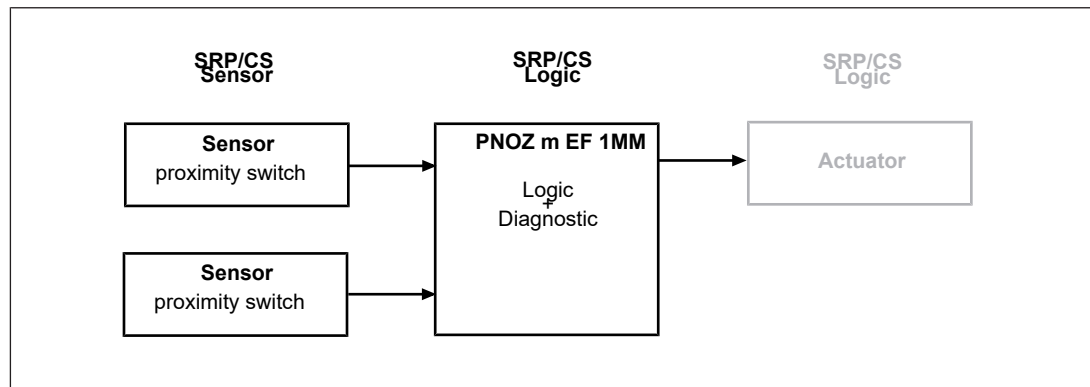

To calculate the safety function you will need the following data for the "sensor" subsystem and the subsystem "PNOZ m EF 1MM":

Sensor			Subsystem PNOZ m EF 1MM	
Category	MTTFd	DC	Operating mode	PFH (1/h)
4	Manufacturer-specific	90 %	Monitoring 2 sensors	1,35E-09

In a worst case scenario, the sensor subsystem's characteristic value MTTFd is calculated from the inferior (lower) value of the two sensors.

The values for **DC** refer to the standard EN 61508.

9.1.9.3 Achievable safety level

Monitoring function	PL of EN ISO 13849-1: 2015	SIL CL in accordance with EN IEC 62061
SOS-M SDI-M SS2-M	-	-
SSR-M SSM SS1-M SLA-M SAR-M	PL e (Cat.4)	3

Please note:

Common cause failures (CCF) are possible for the sensor subsystem. An appropriate analysis must be carried out.

To use proximity switches 1 and 2 we recommend that you:

- ▶ Use different technologies/design or physical principles (e.g. different manufacturers) and
- ▶ Evaluate the sensor supply via track S

9.1.10 Safety characteristic data for operation with 2 proximity switches with reduced diagnostics

9.1.10.1 Permitted sensor types and output signals

Non-safety-related sensor

Permitted sensor types:

- ▶ Inductive proximity switches

Permitted output circuits:

- ▶ pnp

9.1.10.2 Safety-related architecture

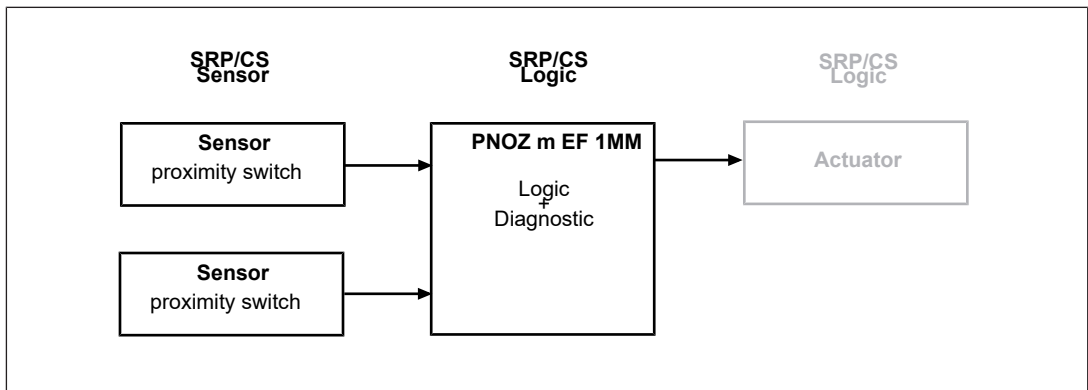

The supply voltage of the proximity switches must be monitored as a measure against systemic failure.

To calculate the safety function you will need the following data for the "sensor" subsystem and the subsystem "PNOZ m EF 1MM":

Sensor			Subsystem PNOZ m EF 1MM	
Category	MTTFd	DC ₁₃₈₄₉	Operating mode	PFH (1/h)
3	Manufacturer-specific	90 %*	Monitoring 2 sensors with reduced diagnostics	1,35E-09

In a worst case scenario, the sensor subsystem's characteristic value MTTFd is calculated from the inferior (lower) value of the two sensors.

The value for DC refers to the standard EN13849

*see EN 13849-1 table E.1

"Cross monitoring of input signals with dynamic test if short circuits are not detectable (for multiple I/O)" → 90%

9.1.10.3 Achievable safety level

Monitoring function	PL of EN ISO 13849-1: 2015	SIL CL in accordance with EN IEC 62061
SOS-M	-	-
SDI-M		
SS2-M		
SSR-M	PL e (Cat.4)	3
SSM		
SS1-M		
SLA-M		
SAR-M		

Please note:

Common cause failures (CCF) are possible for the sensor subsystem. An appropriate analysis must be carried out.

10 Order reference

10.1 Product

Product type	Features	Order no.
PNOZ m EF 1MM	Expansion module	772 170

10.2 Accessories

Connection terminals

Product type	Features	Order no.
Spring terminals PNOZ mmcxp 1 pc.	Spring-loaded terminals, 1 piece	783 542
Screw terminals PNOZ mmcxp 1 pc.	Screw terminals, 1 piece	793 542

Terminator, jumper

Product type	Features	Order no.
PNOZ mm0.xp connector left	Jumper yellow/black to connect the modules, 10 pieces	779 260

Adapter cable

Product type	Features	Order no.
MM A MINI-IO CAB99	1.50 m	772 200
MM A MINI-IO CAB99	2.50 m	772 201
MM A MINI-IO CAB99	5.0 m	772 202

Product type	Features	Order no.
PNOZ msi b4 Box	Connection box	773 845